

Bernard® BTB Semi-Automatic Air-Cooled MIG Gun

OWNER'S MANUAL

February 2024

OM-BTB-3.2

Semi-Automatic, Air-Cooled, MIG
(GMAW) Welding Gun



Tregaskiss.com/TechnicalSupport
1-855-MIGWELD (644-9353)(US & Canada)
+1-519-737-3000(International)

Thank You for Choosing Bernard®

Thank you for selecting a Bernard product. Before installing, compare the equipment received against the invoice to verify that the shipment is complete and undamaged. It is the responsibility of the purchaser to file all claims of damage or loss that may have occurred during transit with the carrier.

The owner's manual contains general information, instructions and maintenance to help better maintain your MIG gun or peripheral. Please read, understand and follow all safety precautions.

While every precaution has been taken to assure the accuracy of this owner's manual, Bernard assumes no responsibility for errors or omissions. Bernard assumes no liability for damages resulting from the use of information contained herein. The information presented in this owner's manual is accurate to the best of our knowledge at the time of printing. Please reference Tregaskiss.com for updated material.

For customer support and special applications, please call the Bernard Customer Service Department at 1-855-MIGWELD (644-9353) (US & Canada) or +1-519-737-3000 (International), fax 1-708-946-6726, or email at cs@itwmig.com. Our trained Customer Service Team is available between 8:00 a.m. and 5:30 p.m. EST, and will answer your product application or repair questions.

Bernard manufactures premium semi-automatic (GMAW) and FCAW (flux-cored) welding guns, consumables, accessories and manual arc products. For more information on other Bernard products, contact your local Bernard distributor or visit us on the web at Tregaskiss.com.

TABLE OF CONTENTS

DECLARATION OF CONFORMITY	V
DECLARATION OF CONFORMITY	VI
SECTION 1 — SAFETY PRECAUTIONS — READ BEFORE USING	1
1-1 Symbol Usage	1
1-2 Arc Welding Hazards	1
1-3 California Proposition 65 Warnings	3
1-4 Principal Safety Standards	3
1-5 EMF Information	3
SECTION 2 — CONSIGNES DE SÉCURITÉ — LIRE AVANT UTILISATION	4
2-1 Symboles utilisés	4
2-2 Dangers relatifs au soudage à l'arc	4
2-3 Proposition californienne 65 avertissements	6
2-4 Principales normes de sécurité	6
2-5 Informations relatives aux CEM	6
SECTION 3 — PRECAUCIONES DE SEGURIDAD — LEA ANTES DE USAR	7
3-1 Uso de símbolos	7
3-2 Peligros en soldadura de arco	7
3-3 Advertencias de la Proposición 65 del estado de California	9
3-4 Estándares principales de seguridad	9
3-5 Información sobre los campos electromagnéticos (EMF)	9
SECTION 4 — PRODUCT WARRANTY	10
4-1 Product Warranty	10
SECTION 5 — SPECIFICATIONS	11
5-1 Specifications	11
5-2 Duty Cycle and Overheating	11
SECTION 6 — INSTALLATION	12
6-1 Installing to a Feeder with a Power Pin	12
6-2 Installing to a Feeder with a Euro or a Bernard® Power Pin	12
SECTION 7 — OPERATION	13
7-1 Pulling the Trigger	13
SECTION 8 — REPLACEMENT	14
8-1 Changing Consumables	14
8-2 Changing AccuLock™ S Consumables	15

8-3 Changing the Liner	16
8-4 Changing the Neck	18
8-5 Changing the Handle and Switch	20
8-6 Changing the Power Pin	22
SECTION 9 — PARTS LIST	23
9-1 B Series Regular and Small Curved Handles with Yellow Trigger	23
9-2 O Series Small Curved Handle with Blue Trigger	24
9-3 O Series Curved Handle with Blue Trigger	25
9-4 T Series Small Straight Handle with Black Trigger	26
9-5 T Series Straight Handle with Silver Trigger	27
9-6 C Series Straight Handle with Black Trigger	28
SECTION 10 — CONSUMABLE PARTS	29
10-1 AccuLock™ S Consumable Series	29
10-2 Centerfire™ Consumable Series	30
10-3 Centerfire HD Consumable Series	31
10-4 TOUGH LOCK® Consumable Series	32
SECTION 11 — TROUBLESHOOTING	34
11-1 Troubleshooting Table	34
NOTES	36
ADDITIONAL SUPPORT MATERIALS	37

DECLARATION OF CONFORMITY

for European Community (CE marked) products



Bernard, 449 West Corning Rd., Beecher, IL 60401 U.S.A. declares that the product(s) identified in this declaration conform to the essential requirements and provisions of the stated Council Directive(s) and Standard(s).

Product/Apparatus Identification:

Product	Stock Number
Bernard Q20 Series – 200A	Q20XXXXXXXX (Configurable #)
Bernard Q30 Series – 300A	Q30XXXXXXXX (Configurable #)
Bernard Q40 Series – 400A	Q40XXXXXXXX (Configurable #)

Council Directives:

- 2014/35/EU Low voltage
- 2011/65/EU and amendment 2015/863 Restriction of the use of certain hazardous substances in electrical and electronic equipment

Electronic equipment standards:

- EN IEC 60974-7:2019 Arc welding equipment – Part 7: Torches
- EN IEC 63000:2018 Technical documentation for the assessment of electrical and electronic products with respect to the restriction of hazardous substances

Signatory:

March 16, 2014

David A. Werba
MANAGER, PRODUCT DESIGN COMPLIANCE

Date of Declaration

DECLARATION OF CONFORMITY

for United Kingdom(UKCA marked) products



Bernard, 449 West Corning Rd., Beecher, IL 60401 U.S.A. declares that the product(s) identified in this declaration conform to the essential requirements and provisions of the stated Council Directive(s) and Standard(s).

Product/Apparatus Identification:

Product	Stock Number
Bernard Q20 Series – 200A	Q20XXXXXXXX (Configurable #)
Bernard Q30 Series – 300A	Q30XXXXXXXX (Configurable #)
Bernard Q40 Series – 400A	Q40XXXXXXXX (Configurable #)

Council Directives:

- S.I. 2016/1101 Electrical Equipment (Safety) Regulations 2016
- S.I. 2012/3032 Restriction of the Use of Certain Hazardous Substances in Electrical and Electronic Equipment Regulations

Electronic equipment standards:

- EN IEC 60974-7:2019 Arc welding equipment – Part 7: Torches
- EN IEC 63000:2018 Technical documentation for the assessment of electrical and electronic products with respect to the restriction of hazardous substances

Signatory:

March 16, 2014

David A. Werba
MANAGER, PRODUCT DESIGN COMPLIANCE

Date of Declaration



SECTION 1 — SAFETY PRECAUTIONS — READ BEFORE USING



Protect yourself and others from injury – read, follow, and save these important safety precautions and operating instructions.

1-1 Symbol Usage



DANGER! – Indicates a hazardous situation which, if not avoided, will result in death or serious injury. The possible hazards are shown in the adjoining symbols or explained in the text.



Indicates a hazardous situation which, if not avoided, could result in death or serious injury. The possible hazards are shown in the adjoining symbols or explained in the text.

NOTICE – Indicates statements not related to personal injury.

 – Indicates special instructions.



This group of symbols means Warning! Watch Out! ELECTRIC SHOCK, MOVING PARTS, and HOT PARTS hazards. Consult symbols and related instructions below for necessary actions to avoid the hazards.

1-2 Arc Welding Hazards



The symbols shown below are used throughout this manual to call attention to and identify possible hazards. When you see the symbol, watch out, and follow the related instructions to avoid the hazard. The safety information given below is only a summary of the more complete safety information found in section 1-4 Principal Safety Standards on page 3, and in welding power source Owner's Manual. Read and follow all Safety Standards.



Only qualified persons should install, operate, maintain, and repair this equipment. A qualified person is defined as one who, by possession of a recognized degree, certificate, or professional standing, or who by extensive knowledge, training and experience, has successfully demonstrated ability to solve or resolve problems relating to the subject matter, the work, or the project and has received safety training to recognize and avoid the hazards involved.



During operation, keep everybody, especially children, away.

ELECTRIC SHOCK can kill.

- Always wear dry insulating gloves.
- Insulate yourself from work and ground.
- Do not touch live electrode or electrical parts.



- Replace worn, damaged, or cracked guns or cables.
- Turn off welding power source before changing contact tip or gun parts.
- Keep all covers and handle securely in place.

FUMES AND GASES can be hazardous.

- Keep your head out of the fumes.
- Ventilate area, or use breathing device. The recommended way to determine adequate ventilation is to sample for the composition and quantity of fumes and gases to which personnel are exposed.
- Read and understand the Safety Data Sheets (SDSs) and the manufacturer's instructions for adhesives, coatings, cleaners, consumables, coolants, degreasers, fluxes, and metals.



MOVING PARTS can injure.

- Keep away from moving parts.
- Keep away from pinch points such as drive rolls.



WELDING can cause fire or explosion.

- Do not weld near flammable material.
- Do not weld on containers that have held combustibles, or on closed containers such as tanks, drums, or pipes unless they are properly prepared according to AWS F4.1 and AWS A6.0 (see Safety Standards).
- Watch for fire; keep extinguisher nearby.
- Read and understand the Safety Data Sheets (SDSs) and the manufacturer's instructions for adhesives, coatings, cleaners, consumables, coolants, degreasers, fluxes, and metals.



BUILDUP OF GAS can injure or kill.

- Shut off compressed gas supply when not in use.
- Always ventilate confined spaces or use approved air-supplied respirator.



ARC RAYS can burn eyes and skin.

Arc rays from the welding process produce intense visible and invisible (ultraviolet and infrared) rays that can burn eyes and skin. Sparks fly off from the weld.



- Wear an approved welding helmet fitted with a proper shade of filter lenses to protect your face and eyes from arc rays and sparks when welding or watching (see ANSI Z49.1 and Z87.1 listed in Safety Standards).
- Wear approved safety glasses with side shields under your helmet.
- Use protective screens or barriers to protect others from flash, glare and sparks; warn others not to watch the arc.
- Wear body protection made from leather or flame-resistant clothing (FRC). Body protection includes oil-free clothing such as leather gloves, heavy shirt, cuffless trousers, high shoes, and a cap.

HOT PARTS can burn.

- Allow gun to cool before touching.
- Do not touch hot metal.
- Protect hot metal from contact by others.



NOISE can damage hearing.

Noise from some processes or equipment can damage hearing.



- Check for noise level limits exceeding those specified by OSHA.
- Use approved ear plugs or ear muffs if noise level is high.
- Warn others nearby about noise hazard.

WELDING WIRE can injure.

- Keep hands and body away from gun tip when trigger is pressed.



READ INSTRUCTIONS.

- Read and follow all labels and the Owner's Manual carefully before installing, operating, or servicing unit. Read the safety information at the beginning of the Manual and in each section.
- Use only genuine replacement parts from the manufacturer.
- Perform installation, maintenance, and service according to the Owner's Manuals, industry standards, and national, state, and local codes.

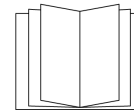

1-3 California Proposition 65 Warnings



WARNING: This product can expose you to chemicals including lead, which are known to the state of California to cause cancer and birth defects or other reproductive harm.

For more information, go to www.P65Warnings.ca.gov.

1-4 Principal Safety Standards

Safety in Welding, Cutting, and Allied Processes, American Welding Society standard ANSI Standard Z49.1. Website: www.aws.org.

Safe Practice For Occupational And Educational Eye And Face Protection, ANSI Standard Z87.1, from American National Standards Institute. Website: www.ansi.org.

Safe Practices for the Preparation of Containers and Piping for Welding and Cutting, American Welding Society Standard AWS F4.1. Website: www.aws.org.

National Electrical Code, NFPA Standard 70 from National Fire Protection Association. Website: www.nfpa.org.

Safe Handling of Compressed Gases in Cylinders, CGA Pamphlet P-1 from Compressed Gas Association. Website: www.cganet.com.

Safety in Welding, Cutting, and Allied Processes, CSA Standard W117.2 from Canadian Standards Association. Website: www.csagroup.org.

Standard for Fire Prevention During Welding, Cutting, and Other Hot Work, NFPA Standard 51B from National Fire Protection Association. Website: www.nfpa.org.

OSHA, Occupational Safety and Health Standards for General Industry, Title 29, Code of Federal Regulations (CFR), Part 1910.177 Subpart N, Part 1910 Subpart Q, and Part 1926, Subpart J. Website: www.osha.gov.

SR7 2022-01

1-5 EMF Information

Electric current flowing through any conductor causes localized electric and magnetic fields (EMF). The current from arc welding (and allied processes including spot welding, gouging, plasma arc cutting, and induction heating operations) creates an EMF field around the welding circuit. EMF fields may interfere with some medical implants, e.g. Pacemakers. Protective measures for persons wearing medical implants have to be taken. For example, restrict access for passersby or conduct individual risk assessment for welders. All welders should use the following procedures in order to minimize exposure to EMF fields from the welding circuit:

1. Keep cables close together by twisting or taping them, or using a cable cover.
2. Do not place your body between welding cables. Arrange cables to one side and away from the operator.

3. Do not coil or drape cables around your body.
4. Keep head and trunk as far away from the equipment in the welding circuit as possible.
5. Connect work clamp to workpiece as close to the weld as possible.
6. Do not work next to, sit or lean on the welding power source.
7. Do not weld whilst carrying the welding power source wire feeder.

About Implanted Medical Devices:

Implanted Medical Device wearers should consult their doctor and the device manufacturer before performing or going near arc welding, spot welding, gouging, plasma arc cutting, or induction heating operations. If cleared by your doctor, then following the above procedures is recommended.

SECTION 2 — CONSIGNES DE SÉCURITÉ — LIRE AVANT UTILISATION

 Pour écarter les risques de blessure pour vous-même et pour autrui — lire, appliquer et ranger en lieu sûr ces consignes relatives aux précautions de sécurité et au mode opératoire.

2-1 Symboles utilisés

 **DANGER!** – Indique une situation dangereuse qui si on l'évite pas peut donner la mort ou des blessures graves. Les dangers possibles sont montrés par les symboles joints ou sont expliqués dans le texte.

 Indique une situation dangereuse qui si on l'évite pas peut donner la mort ou des blessures graves. Les dangers possibles sont montrés par les symboles joints ou sont expliqués dans le texte.

AVIS – Indique des déclarations pas en relation avec des blessures personnelles.

 – Indique des instructions spécifiques.



Ce groupe de symboles veut dire Avertissement! Attention! DANGER DE CHOC ELECTRIQUE, PIECES EN MOUVEMENT, et PIECES CHAUDES. Reportez-vous aux symboles et aux directives cidessous afin de connaître les mesures à prendre pour éviter tout danger.

2-2 Dangers relatifs au soudage à l'arc

 Les symboles donnés ci-après sont utilisés dans tout le manuel pour attirer l'attention sur les dangers possibles et pour indiquer le type de danger dont il s'agit. Quand on voit le symbole, prendre garde et suivre les directives correspondantes pour éviter le danger. Les consignes de sécurité présentées ci-après ne font que résumer l'information contenue dans les Normes de sécurité principales, et dans le Guide d'utilisation de la source de courant de soudage. Lire et suivre toutes les Normes de sécurité.

 L'installation, l'utilisation, l'entretien et les réparations ne doivent être confiés qu'à des personnes qualifiées. Une personne qualifiée est définie comme celle qui, par la possession d'un diplôme reconnu, d'un certificat ou d'un statut professionnel, ou qui, par une connaissance, une formation et une expérience approfondies, a démontré avec succès sa capacité à résoudre les problèmes liés à la tâche, le travail ou le projet et a reçu une formation en sécurité afin de reconnaître et d'éviter les risques inhérents.

 Au cours de l'utilisation, tenir toute personne à l'écart et plus particulièrement les enfants.

UN CHOC ÉLECTRIQUE peut tuer.



- Porter toujours des gants secs et isolants.
- S'isoler de la pièce et de la terre.
- Ne jamais toucher une électrode ou des pièces électriques sous tension.
- Remplacer les pistolets ou câbles de soudage qui sont endommagés, usés ou craquelés.
- Mettre la soudeuse hors tension avant de remplacer un bec contact ou des pièces de pistolet.
- S'assurer que tous les couvercles et poignées sont fermement assujettis.

LES FUMÉES ET LES GAZ peuvent être dangereux.



- Garder la tête hors des fumées.
- Aérer la zone de travail ou porter un appareil respiratoire. Pour déterminer la bonne ventilation, il est recommandé de procéder à un prélèvement pour la composition et la quantité de fumées et de gaz auxquels est exposé le personnel.
- Lire et comprendre les fiches de données de sécurité et les instructions du fabricant concernant les adhésifs, les revêtements, les nettoyants, les consommables, les produits de refroidissement, les dégraissants, les flux et les métaux.

Les PIÈCES MOBILES peuvent causer des blessures.



- Ne pas s'approcher des organes mobiles.
- Ne pas s'approcher des points de coincement tels que des rouleaux de commande.

Le SOUDAGE peut provoquer un incendie ou une explosion.



- Ne pas souder à proximité de matériaux inflammables
- Ne pas effectuer le soudage sur des conteneurs fermés tels que des réservoirs, tambours, ou conduites, à moins qu'ils n'aient été préparés correctement conformément à AWS F4.1 et AWS A6.0 (voir les Normes de Sécurité).
- Prendre garde aux incendies et toujours avoir un extincteur à proximité.

- Lire et comprendre les fiches de données de sécurité et les instructions du fabricant concernant les adhésifs, les revêtements, les nettoyants, les consommables, les produits de refroidissement, les dégraissateurs, les flux et les métaux.

L'ACCUMULATION DE GAZ risquent de provoquer des blessures ou même la mort.



- Fermer l'alimentation du gaz comprimé en cas de non utilisation.
- Veiller toujours à bien aérer les espaces confinés ou se servir d'un respirateur d'adduction d'air homologué.

LE RAYONNEMENT DE L'ARC peut brûler les yeux et la peau.



Le rayonnement de l'arc du procédé de soudage génère des rayons visibles et invisibles intenses (ultraviolets et infrarouges) susceptibles de provoquer des brûlures dans les yeux et sur la peau. Des étincelles sont projetées pendant le soudage.

- Porter un casque de soudage approuvé muni de verres filtrants approprié pour protéger visage et yeux pendant le soudage (voir ANSI Z49.1 et Z87.1 énuméré dans les normes de sécurité).
- Porter des lunettes de sécurité avec écrans latéraux même sous votre casque.
- Avoir recours à des écrans protecteurs ou à des rideaux pour protéger les autres contre les rayonnements les éblouissements et les étincelles ; prévenir toute personne sur les lieux de ne pas regarder l'arc.
- Porter une protection corporelle en cuir ou des vêtements ignifuges (FRC). La protection du corps comporte des vêtements sans huile, comme des gants de cuir, une chemise solide, des pantalons sans revers, des chaussures hautes et une casquette.

LES PIÈCES CHAUDES peuvent provoquer des brûlures.



- Laisser refroidir le pistolet avant de le toucher.
- Ne pas toucher d'objets métalliques chauds.
- Abrisser les objets métalliques contre tout contact par les personnes à proximité.

Le BRUIT peut endommager l'ouïe.

Le bruit des processus et des équipements peut affecter l'ouïe.



- Vérifier si les niveaux de bruit excèdent les limites spécifiées par l'OSHA.
- Utiliser des bouches-oreilles ou des serre-tête antibruit approuvés si le niveau de bruit est élevé.

- Avertir les personnes à proximité au sujet du danger inhérent au bruit.

LES FILS DE SOUDAGE peuvent provoquer des blessures.



- Éloigner les mains et le corps de la buse du pistolet après avoir appuyé sur la gâchette.

LIRE LES INSTRUCTIONS.

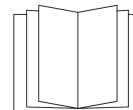

- Lire et appliquer les instructions sur les étiquettes et le Mode d'emploi avant l'installation, l'utilisation ou l'entretien de l'appareil. Lire les informations de sécurité au début du manuel et dans chaque section.
- N'utiliser que les pièces de remplacement provenant du fabricant.
- Effectuer l'installation, l'entretien et toute intervention selon les manuels d'utilisateurs, les normes nationales, provinciales et de l'industrie, ainsi que les codes municipaux.

2-3 Proposition californienne 65 avertissements



AVERTISSEMENT – Ce produit peut vous exposer à des produits chimiques tels que le plomb, reconnus par l'État de Californie comme cancérigènes et sources de malformations ou d'autres troubles de la reproduction

Pour plus d'informations, consulter www.P65Warnings.ca.gov.

2-4 Principales normes de sécurité

Safety in Welding, Cutting, and Allied Processes, American Welding Society standard ANSI Standard Z49.1. Website: www.aws.org.

Safe Practice For Occupational And Educational Eye And Face Protection, ANSI Standard Z87.1, from American National Standards Institute. Website: www.ansi.org.

Safe Practices for the Preparation of Containers and Piping for Welding and Cutting, American Welding Society Standard AWS F4.1 from Global Engineering Documents. Website: www.aws.org.

National Electrical Code, NFPA Standard 70 from National Fire Protection Association. Website: www.nfpa.org.

Safe Handling of Compressed Gases in Cylinders, CGA Pamphlet P-1 from Compressed Gas Association. Website: www.cganet.com.

Safety in Welding, Cutting, and Allied Processes, CSA Standard W117.2 from Canadian Standards Association. Website: www.csagroup.org.

Standard for Fire Prevention During Welding, Cutting, and Other Hot Work, NFPA Standard 51B from National Fire Protection Association. Website: www.nfpa.org.

OSHA, Occupational Safety and Health Standards for General Industry, Title 29, Code of Federal Regulations (CFR), Part 1910.177 Subpart N, Part 1910 Subpart Q, and Part 1926, Subpart J. Website: www.osha.gov.

SR7_fre 2022-01

2-5 Informations relatives aux CEM

Le courant électrique qui traverse tout conducteur génère des champs électromagnétiques (CEM) à certains endroits. Le courant issu d'un soudage à l'arc (et de procédés connexes, y compris le soudage par points, le gougeage, le découpage plasma et les opérations de chauffage par induction) crée un champ électromagnétique (CEM) autour du circuit de soudage. Les champs électromagnétiques produits peuvent causer interférence à certains implants médicaux, p. ex. les stimulateurs cardiaques. Des mesures de protection pour les porteurs d'implants médicaux doivent être prises: par exemple, des restrictions d'accès pour les passants ou une évaluation individuelle des risques pour les soudeurs. Tous les soudeurs doivent appliquer les procédures suivantes pour minimiser l'exposition aux CEM provenant du circuit de soudage:

1. Rassembler les câbles en les torsadant ou en les attachant avec du ruban adhésif ou avec une housse.
2. Ne pas se tenir au milieu des câbles de soudage. Disposer les câbles d'un côté et à distance de l'opérateur.

3. Ne pas courber et ne pas entourer les câbles autour de votre corps.
4. Maintenir la tête et le torse aussi loin que possible du matériel du circuit de soudage.
5. Connecter la pince sur la pièce aussi près que possible de la soudure.
6. Ne pas travailler à proximité d'une source de soudage, ni s'asseoir ou se pencher dessus.
7. Ne pas souder tout en portant la source de soudage ou le dévidoir.

En ce qui concerne les implants médicaux :

Les porteurs d'implants doivent d'abord consulter leur médecin avant de s'approcher des opérations de soudage à l'arc, de soudage par points, de gougeage, du coupage plasma ou de chauffage par induction. Si le médecin approuve, il est recommandé de suivre les procédures précédentes.

SECTION 3 — PRECAUCIONES DE SEGURIDAD — LEA ANTES DE USAR

 Protéjase usted mismo y a otros contra lesiones — lea, cumpla y conserve estas importantes precauciones de seguridad e instrucciones de utilización.

3-1 Uso de símbolos

 **PELIGRO!** — Indica una situación peligrosa que, si no se la evita, resultará en muerte o lesión grave. Los peligros posibles se muestran en los símbolos adjuntos o se explican en el texto.

 Indica una situación peligrosa que, si no se la evita, podría resultar en muerte o lesión grave. Los peligros posibles se muestran en los símbolos adjuntos, o se explican en el texto.

AVISO — Indica precauciones no relacionadas a lesiones personales.

 — Indica instrucciones especiales.



Este grupo de símbolos significa ¡Advertencia!, ¡Cuidado! CHOQUE O DESCARGA ELÉCTRICA, PIEZAS QUE SE MUEVEN, y peligros de PARTES CALIENTES. Consulte los símbolos y las instrucciones relacionadas que aparecen a continuación para ver las acciones necesarias para evitar estos peligros.

3-2 Peligros en soldadura de arco

 Los símbolos mostrados abajo se usan en todo este manual para llamar la atención a e identificar los posibles peligros. Cuando vea el símbolo, preste atención y siga las instrucciones relacionadas para evitar el peligro. La información de seguridad dada abajo es solamente un resumen de la información más completa de seguridad que se encuentra en los estándares de seguridad, y la fuente de alimentación para soldadura del Manual del usuario. Lea y siga todas las normas de seguridad.

 Solamente personal cualificado debe instalar, utilizar, mantener y reparar este equipo. La definición de personal cualificado es cualquier persona que, debido a que posee un título, un certificado o una posición profesional reconocida, o gracias a su gran conocimiento, capacitación y experiencia, haya demostrado con éxito la capacidad para solucionar o resolver problemas relacionados con el trabajo, el proyecto o el tema en cuestión, además de haber asistido a una capacitación en seguridad para reconocer y evitar los peligros que implica el proceso.

 Durante su operación mantenga lejos a todos, especialmente a los niños.

UNA DESCARGA ELÉCTRICA puede matarlo.



- Siempre use guantes aislantes secos.
- Aíslese usted mismo del trabajo y la tierra.
- No toque electrodo eléctricamente vivo o partes eléctricamente vivas.
- Reemplace antorchas o cables desgastados, dañados o rotos.
- Repare o reemplace aislamiento de la pistola o del cable que esté desgastado, dañado o agrietado.
- Apague la máquina de soldar antes de cambiar los tubos de contacto o piezas de la antorcha.
- Mantenga todas las tapas y asa bien seguras en sitio.

HUMO y GASES pueden ser peligrosos.



- Mantenga su cabeza fuera del humo.
- Ventile el lugar o use un aparato para respirar. El método recomendado para determinar la ventilación adecuada es tomar muestras de la composición y cantidad de humos y gases a los que está expuesto el personal.
- Lea y entienda las Hojas de datos del material (SDS) y las instrucciones del fabricante relacionadas con los adhesivos, metales, consumibles, recubrimientos, limpiadores, refrigerantes, desengrasadores, fundentes y metales.

Las PIEZAS MÓVILES pueden provocar lesiones.



- Aléjese de toda parte en movimiento.
- Aléjese de todo punto que pellizque, tal como rodillos impulsados.

EL SOLDAR puede causar fuego o explosión.



- No suelde cerca de material inflamable
- No suelde en recipientes que han contenido combustibles, ni en recipientes cerrados como tanques, tambores o tuberías, a menos que estén preparados correctamente de acuerdo con la norma AWS F4.1 y AWS A6.0 (vea las normas de seguridad).
- Siempre mire que no haya fuego y mantenga un extinguidor de fuego cerca.
- Lea y entienda las Hojas de datos del material (SDS) y las instrucciones del fabricante relacionadas con los adhesivos, metales, consumibles, recubrimientos, limpiadores, refrigerantes, desengrasadores, fundentes y metales.

EL AMONTONAMIENTO DE GAS puede enfermarle o matarle.



- Cierre el suministro de gas comprimido cuando no lo use.
- Siempre dé ventilación a espacios cerrados o use un respirador aprobado que reemplaza el aire.

LOS RAYOS DEL ARCO pueden quemar sus ojos y piel.



Los rayos del arco de un proceso de suelda producen un calor intenso y rayos ultravioletas fuertes que pueden quemar los ojos y la piel. Las chispas se escapan de la soldadura.

- Use una careta para soldar aprobada equipada con un filtro de protección apropiado para proteger su cara y ojos de los rayos del arco y de las chispas mientras esté soldando o mirando. (véase los estándares de seguridad ANSI Z49.1 y Z87.1).
- Use anteojos de seguridad aprobados que tengan protección lateral.
- Use pantallas de protección o barreras para proteger a otros del destello, reflejos y chispas, alerte a otros que no miren el arco.
- Use protección para el cuerpo hecha de cuero o de prendas resistentes a las llamas (FRC). Entre la protección para el cuerpo se incluye la ropa sin aceite, como guantes de cuero, una camisa gruesa, pantalones sin vuelta, calzado alto y una gorra.

PARTES CALIENTES pueden causar quemaduras severas.



- Permita que la antorcha se enfríe antes de tocarla.
- No toque metal caliente.
- Proteja a otros del contacto con el metal caliente.

EL RUIDO puede trastornar su oído.



Ruido proveniente de algunos procesos o equipo puede dañar el oído.

- Chequee los límites del nivel del ruido si exceden aquellos especificados por OSHA.
- Use tapas para los oídos o cubiertas para los oídos si el nivel del ruido es demasiado alto.
- Advierta a otros que estén cerca acerca del peligro del ruido.

El ALAMBRE de SOLDAR puede causarle heridas.



- Mantenga las manos y el cuerpo lejos del tubo de contacto de la antorcha cuando se haya presionado el gatillo.

LEER INSTRUCCIONES.

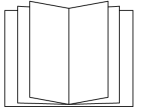

- Lea y siga cuidadosamente las instrucciones contenidas en todas las etiquetas y en el Manual del usuario antes de instalar, utilizar o realizar tareas de mantenimiento en la unidad. Lea la información de seguridad incluida en la primera parte del manual y en cada sección.
- Utilice únicamente piezas de reemplazo legítimas del fabricante.
- Los trabajos de instalación y mantenimiento deben ser ejecutados de acuerdo con las instrucciones del manual del usuario, las normas del sector y los códigos nacionales, estatales y locales.

3-3 Advertencias de la Proposición 65 del estado de California



ADVERTENCIA: Este producto puede exponerlo a químicos, incluso plomo, que el estado de California conoce como causantes de cáncer, defectos de nacimiento u otros daños reproductivos.

Para obtener más información, acceda a www.P65Warnings.ca.gov.

3-4 Estándares principales de seguridad

Safety in Welding, Cutting, and Allied Processes, American Welding Society standard ANSI Standard Z49.1. Website: www.aws.org.

Safe Practice For Occupational And Educational Eye And Face Protection, ANSI Standard Z87.1, from American National Standards Institute. Website: www.ansi.org.

Safe Practices for the Preparation of Containers and Piping for Welding and Cutting, American Welding Society Standard AWS F4.1 from Global Engineering Documents. Website: www.aws.org.

National Electrical Code, NFPA Standard 70 from National Fire Protection Association. Website: www.nfpa.org.

Safe Handling of Compressed Gases in Cylinders, CGA Pamphlet P-1 from Compressed Gas Association. Website: www.cganet.com.

Safety in Welding, Cutting, and Allied Processes, CSA Standard W117.2 from Canadian Standards Association. Website: www.csagroup.org.

Standard for Fire Prevention During Welding, Cutting, and Other Hot Work, NFPA Standard 51B from National Fire Protection Association. Website: www.nfpa.org.

OSHA, Occupational Safety and Health Standards for General Industry, Title 29, Code of Federal Regulations (CFR), Part 1910.177 Subpart N, Part 1910 Subpart Q, and Part 1926, Subpart J. Website: www.osha.gov.

SR7_spa 2022-01

3-5 Información sobre los campos electromagnéticos (EMF)

La corriente que fluye a través de un conductor genera campos eléctricos y magnéticos (EMF) localizados. La corriente del arco de soldadura (y otras técnicas afines como la soldadura por puntos, el ranurado, el corte por plasma y el calentamiento por inducción) genera un campo EMF alrededor del circuito de soldadura. Los campos EMF pueden interferir con algunos dispositivos médicos implantados como, por ejemplo, los marcapasos. Por lo tanto, se deben tomar medidas de protección para las personas que utilizan estos implantes médicos. Por ejemplo, aplique restricciones al acceso de personas que pasan por las cercanías o realice evaluaciones de riesgo individuales para los soldadores. Todos los soldadores deben seguir los procedimientos que se indican a continuación con el objeto de minimizar la exposición a los campos EMF generados por el circuito de soldadura:

1. Mantenga los cables juntos retorciéndolos entre sí o uniéndolos mediante cintas o una cubierta para cables.
2. No ubique su cuerpo entre los cables de soldadura. Disponga los cables a un lado y apartelos del operario.

3. No enrolle ni cuelgue los cables sobre su cuerpo.
4. Mantenga la cabeza y el tronco tan apartados del equipo del circuito de soldadura como le sea posible.
5. Conecte la pinza de masa en la pieza lo más cerca posible de la soldadura.
6. No trabaje cerca de la fuente de alimentación para soldadura, ni se siente o recueste sobre ella.
7. No suelde mientras transporta la fuente de alimentación o el alimentador de alambre.

Acerca de los aparatos médicos implantados:

Las personas que usen aparatos médico implantados deben consultar con su médico y el fabricante del aparato antes de llevar a cabo o acercarse a soldadura de arco, soldadura de punto, ranurar, hacer corte por plasma, u operaciones de calentamiento por inducción. Si su doctor lo permite, entonces siga los procedimientos de arriba.

SECTION 4 — PRODUCT WARRANTY

4-1 Product Warranty

Limited Warranty

Tregaskiss' Products shall, from the date of original purchase (or, solely with respect to Low Stress Robotic Unicables packaged with any Tregaskiss® Robotic MIG Gun, from the date the product goes into production for its intended use) and for the period set forth below, be free from defects in material and workmanship. To obtain repair or replacement of any Product, the covered Product must be delivered, transportation pre-paid by Purchaser, to the address specified by Tregaskiss on its Returned Materials Authorization, with: (i) written proof of warranty coverage (e.g., Purchaser dated purchase order); (ii) serial number on product (if any); (iii) the Product's installed location within Purchaser's facility and usage of the Product; and (iv) written specification of any alleged defect(s). In the event the foregoing materials are not timely provided to Tregaskiss by claimant, warranty coverage will be determined by Tregaskiss, in its sole discretion. For the avoidance of doubt, the warranty period for any Product or part/component of any Product that is replaced or repaired by Tregaskiss under the foregoing warranty is not extended or renewed at the time of such replacement or repair. **The Warranty against defects does not apply to: (1) consumable components or ordinary wear items; (2) products which are improperly altered, modified, stored, installed, operated, handled, used or neglected or use of the Products with equipment, components or parts not specified or supplied by Tregaskiss or contemplated under the Product documentation; or (3) Products which have not been operated, maintained, and repaired pursuant to Product documentation provided by Tregaskiss. Purchaser shall pay Tregaskiss for all warranty claim costs incurred by Tregaskiss (including inspection, labor, parts, testing, scrap and freight) due to warranty claims submitted by Purchaser which are not covered by Tregaskiss' warranty.**

- Bernard® BTB Semi-Automatic Air-Cooled MIG Guns: **1 year**; *Lifetime warranty on straight handles, straight handle switches, and rear strain relief*
- Bernard® W-Gun™ and T-Gun™ Semi-Automatic Water-Cooled MIG Guns: **180 days**
- Bernard® TGX® Chassis and Bernard TGX Ready To Weld MIG Guns: **90 days**
- Tregaskiss® Robotic MIG Guns and Components: **1 year**
- Tregaskiss® Automatic MIG Guns: **1 year**
- Tregaskiss® TOUGH GUN® Reamer:
 - When factory-equipped with lubricator: **2 years** when factory-equipped with lubricator
 - When (i) factory-equipped with lubricator and (ii) used exclusively with Tregaskiss® TOUGH GARD® Anti-Spatter Liquid: **3 years** when both (i) and (ii)
- Tregaskiss® TOUGH GUN® Robotic Peripheral (Clutch, Sprayer, Wire Cutter, Arms): **1 year**
- Tregaskiss® Low-Stress Robotic Unicables (LSR+ Unicables): **6 months**

Service Warranty

Tregaskiss warrants the Services shall conform to any mutually agreed upon specifications or statements of work. Purchaser's sole remedy, and Tregaskiss's sole liability, for a breach of the foregoing warranty is for Tregaskiss, at its option, to re-perform the Services or credit Purchaser's account for such Services.

Limitation of Liability and Remedies

TREGASKISS WILL NOT BE LIABLE, AND PURCHASER WAIVES ALL CLAIMS AGAINST TREGASKISS FOR INDIRECT, INCIDENTAL, SPECIAL, PUNITIVE OR CONSEQUENTIAL DAMAGES, DOWN TIME, LOST PROFITS OR COMMERCIAL LOSSES, WHETHER OR NOT BASED UPON TREGASKISS' NEGLIGENCE OR BREACH OF WARRANTY OR STRICT LIABILITY IN TORT OR ANY OTHER CAUSE OF ACTION. IN NO EVENT WILL TREGASKISS' LIABILITY IN CONNECTION WITH THE AGREEMENT OR SALE OF TREGASKISS' PRODUCTS OR SERVICES EXCEED THE PURCHASE PRICE OF THE SPECIFIC PRODUCTS OR SERVICES AS TO WHICH THE CLAIM IS MADE.

SECTION 5 — SPECIFICATIONS

5-1 Specifications

Air-Cooled MIG Guns for GMAW Welding

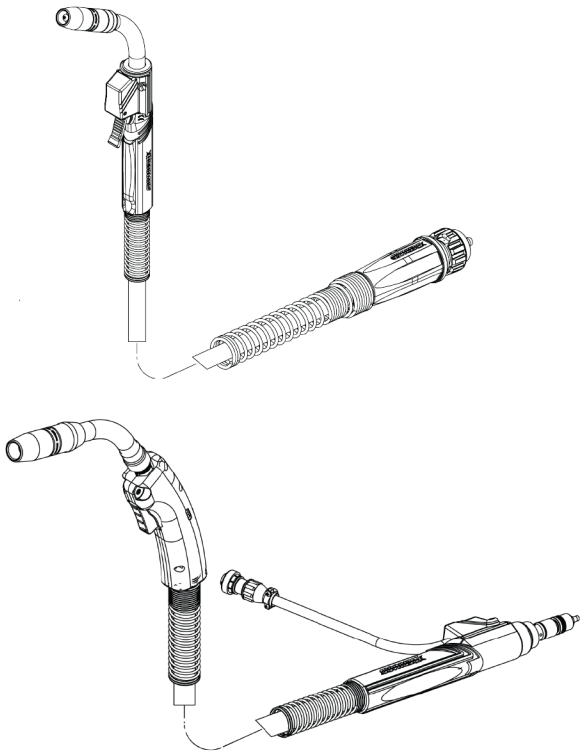

200 amp gun feeds maximum wire size of 1/16" (1.6 mm)

Duty Cycle Rating:

100%: 200 amp with CO₂ Shielding Gas
60% 200 amp with Mixed Gases

300 amp gun feeds maximum wire size of 5/64" (2.0 mm)

Duty Cycle Rating:

100%: 300 amp with CO₂ Shielding Gas
60%: 300 amp with Mixed Gases

400 amp gun feeds maximum wire size of 5/64" (2.0 mm)

Duty Cycle Rating:

100%: 400 amp with CO₂ Shielding Gas
60%: 400 amp with Mixed Gases

500 amp gun feeds maximum wire size of 3/32" (2.4 mm)

Duty Cycle Rating:

100%: 500 amp with CO₂ Shielding Gas
60%: 500 amp with Mixed Gases

600 amp gun feeds maximum wire size of 1/8" (3.2 mm)

Duty Cycle Rating:

100%: 600 amp with CO₂ Shielding Gas
60%: 600 amp with Mixed Gases

5-2 Duty Cycle and Overheating



Duty Cycle is percentage of 10 minutes that unit can weld at rated load without overheating.

Using mixed gases other than CO₂ reduces duty cycle ratings 10-50% depending on gas mixture and welding parameters.

Please reference Section 5 — Specifications on page 11 for duty cycle ratings by amperage.



Continuous Welding

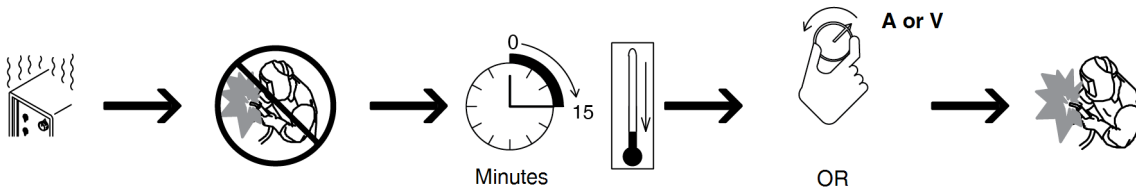

SECTION 6 — INSTALLATION

6-1 Installing to a Feeder with a Power Pin



1. Insert power pin to shoulder and secure tightly.
2. Insert control plug into feeder.
3. Feed welding wire into power pin by hand and tighten drive rolls.

Figure 6-A

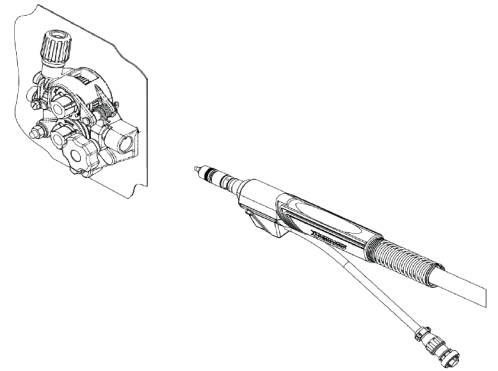

6-2 Installing to a Feeder with a Euro or a Bernard® Power Pin



A. Euro Power Pin

1. Insert the Euro power pin to face of receptacle.
2. Thread Euro hand nut clockwise to tighten.

Figure 6-B

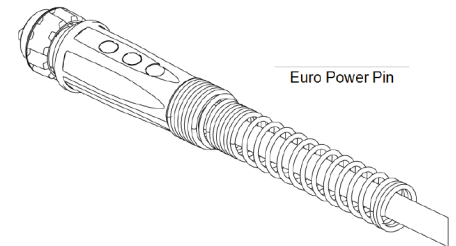

B. Bernard Power Pin

1. Insert the Bernard power pin to face of receptacle.
2. Engage and rotate locking sleeve to tighten.

Figure 6-C

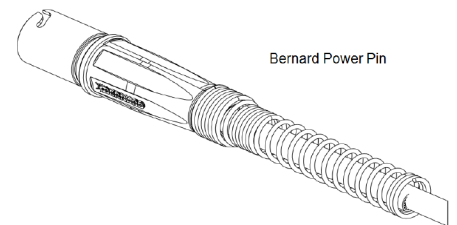

SECTION 7 — OPERATION

7-1 Pulling the Trigger



1. Trigger - When pressed, energized wire feeds and shielding gas flows.

Figure 7-A

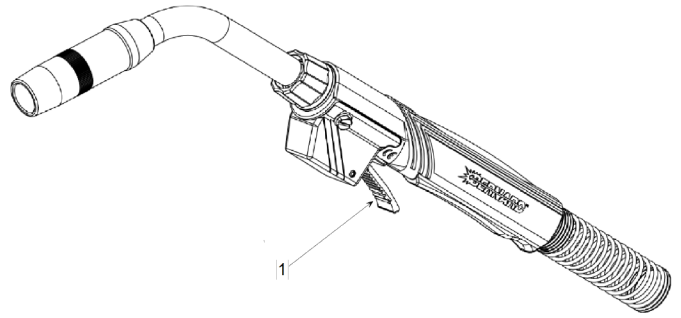
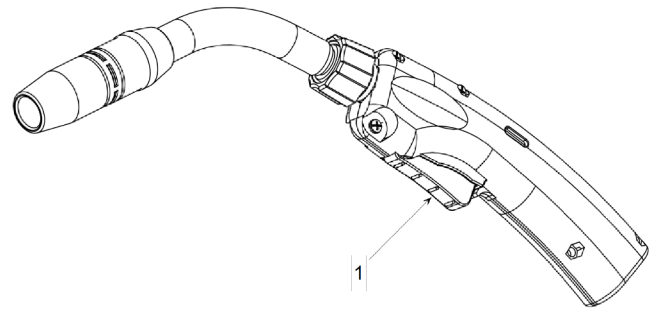

Figure 7-B



SECTION 8 — REPLACEMENT

8-1 Changing Consumables



Figure 8-A

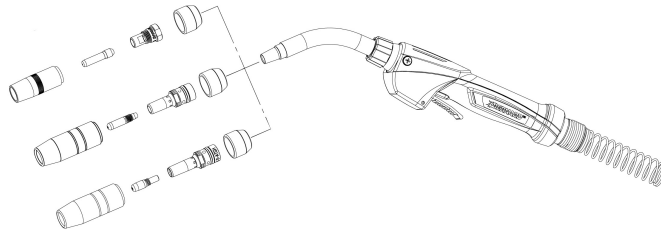

A. Changing AccuLock™ S Consumables

See section 1-1 Changing AccuLock™ S Consumables on page 1.

B. Changing Centerfire™ Consumables

1. Cut electrode and remove all burrs before removing contact tip. Remove threaded nozzle by turning in a counterclockwise direction.
2. Pull the Centerfire contact tip from the gas diffuser. To replace, slide the contact tip over electrode into gas diffuser and lock by installing nozzle onto gas diffuser. Nozzle is used to secure contact tip.
3. Gas diffuser may be removed with an appropriate wrench in a counterclockwise rotation. To install, firmly secure gas diffuser with an appropriate wrench in a counterclockwise rotation. Torque to 144 in-lbs.

C. Changing TOUGH LOCK® Consumables

1. Remove the slip-on nozzle with a twisting and pulling motion.
2. Cut electrode and remove all burrs before removing the contact tip. Remove the TOUGH LOCK contact tip from the retaining head with a counterclockwise turn. To replace, slide the contact tip over electrode into retaining head and lock with a clockwise rotation.
3. Retaining head may be removed with an appropriate wrench in a counterclockwise rotation. To install, firmly secure retaining head with an appropriate wrench in a clockwise rotation. Torque to 144 in-lbs.

D. Changing AccuLock R Consumables

1. Remove the slip-on nozzle with a twisting and pulling motion.
2. Cut electrode and remove all burrs before removing the contact tip. Remove the AccuLock contact tip from the gas diffuser with a counterclockwise turn. To replace, slide the contact tip over electrode into gas diffuser and tighten with a clockwise rotation. Torque to 30 in-lbs (3.5 Nm). **NOTE:** Use Tregaskiss® AccuLock tip tool part # T-ALTOOL for best results.
3. Gas diffuser may be removed with an appropriate wrench in a counterclockwise rotation. To install, firmly secure gas diffuser with an appropriate wrench in a clockwise rotation. Torque to 144 in-lbs.

8-2 Changing AccuLock™ S Consumables



A. Removal

1. Loosen the set screw in the power pin cap and remove the cap from the rear of the gun.
2. Remove the nozzle. Loosen and remove the diffuser.
3. Pull the liner out of the gun from the neck.

B. Installation

1. Insert the heat-shrink end of the liner in through the neck, and push the liner all the way through the gun using short strokes to avoid kinking until the brass end of the liner stops on the neck face.
2. Reinstall gas diffuser by threading in a clockwise rotation. Tighten with a wrench and torque to 144 in-lbs (12 ft-lbs).
3. Reinstall the contact tip by threading into the gas diffuser by hand and tighten with non-marring pliers. Torque to 30 in-lbs (3.5 Nm). **NOTE:** AccuLock tip tool part # T-ALTOOL is recommended.
4. Reinstall the thread-on nozzle by turning clockwise onto the gas diffuser and hand tighten. To reinstall a slip-on nozzle, press the nozzle toward the gas diffuser by hand until you feel a positive stop.
5. Place the power pin cap over the liner extending from the rear of the gun, and thread the cap onto the power pin.
6. Tighten cap snug against the power pin shoulder with welding pliers.
7. Lay the gun straight, making sure there are no twists in the cable. Holding a hex wrench by its shank, tighten the set screw “finger tight” against the liner.
8. Hold the hex wrench by the handle and tighten the set screw an additional half turn (180°) to fully secure the liner.
9. Trim the exposed portion of the liner flush with power pin cap.
10. Insert a piece of welding wire into the liner to check for burrs or obstructions. If needed, loosen screw slightly until wire slides freely.

Figure 8-B

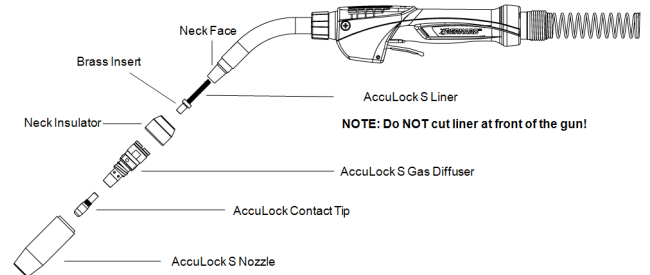
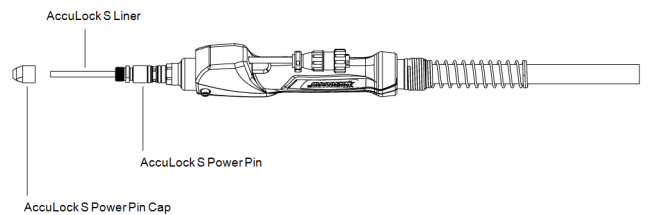

Figure 8-C



8-3 Changing the Liner



A. Changing Bernard Conventional Liner

1. Remove front-end consumables and lay cable straight.
2. Using a 10 mm wrench, turn liner counterclockwise until it is free from the power pin. Remove liner from gun assembly.
3. With cable laying straight, insert new liner into power pin and feed through gun using short strokes to prevent kinking. Twist liner clockwise if necessary.
4. Use a 10 mm wrench to turn liner lock clockwise to tighten into power pin.
5. Trim to dimensions shown in the **New Liner Trim Lengths** chart shown below.
6. Remove all burrs from end of liner and replace gas diffuser retaining head, contact tip and nozzle.

New Liner Trim Lengths		
Centerfire Diffuser Part Number	Liner Trim Length	
D-1	9/16"	14.3 mm
D-1T	13/16"	20.6 mm
D-1T-5	13/16"	20.6 mm
DS-1	9/16"	14.3 mm
DS-1T	5/8"	15.9 mm
DW-1	1/4"	6.4 mm
TOUGH LOCK Retaining Head Part Number	Liner Trim Length	
ALL	3/4"	19.1 mm

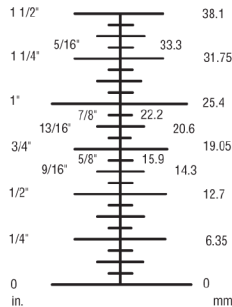

Figure 8-D



B. Changing AccuLock S Liner

See section 1-1 Changing AccuLock™ S Consumables on page 1.

C. Changing QUICK LOAD® Liner

1. Remove the nozzle, contact tip and gas diffuser and lay the cable straight.
2. Pull the QUICK LOAD Liner from the end of the neck using pliers.
3. Remove the protective cap from the new QUICK LOAD Liner and insert it through the neck using the wire as a guide.
4. Feed the liner through the gun using short strokes to prevent kinking.
5. Once the liner stops feeding, give it an extra push to ensure it is seated correctly.
6. Push liner into gun and trim to dimensions shown in **New Liner Trim Lengths** chart on previous page.
7. Remove all burrs from end of liner and replace gas diffuser, contact tip and nozzle.

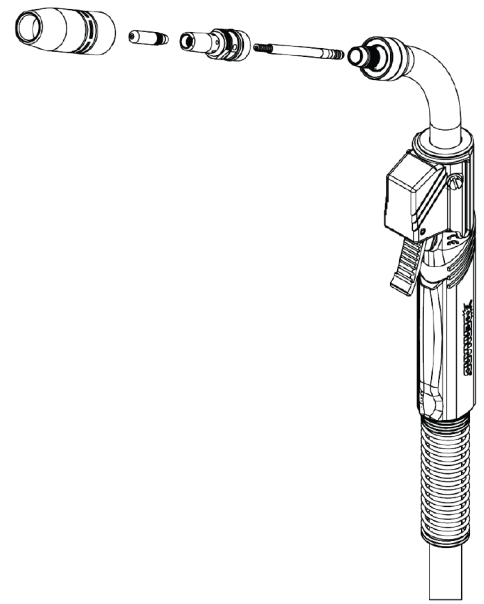

Figure 8-E

D. Changing a Jump Liner

1. Remove the nozzle, contact tip, gas diffuser and neck.
2. Remove used jump liner from the back end of the neck.
3. Insert new jump liner, making sure the liner stop is fully seated at the back of the neck.
4. Take the tapered end of the neck and insert into end fitting of the gun handle.
5. Install the neck.
6. Trim jump liner to dimensions shown in **New Liner Trim Lengths** change on previous page.
7. Deburr the jump liner past the nozzle end of the neck.
8. Install gas diffuser, contact tip and nozzle.

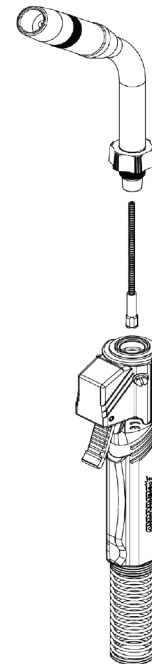

Figure 8-F

8-4 Changing the Neck



A. Changing the Neck - Rotatable

1. To remove neck, grasp lock nut and rotate counterclockwise. Rotation will free neck from end fitting.
2. To install neck, perform the above step in reverse order and torque to 38 in-lbs.
3. Liner may need to be changed if switching to a neck of different bend angle or length.

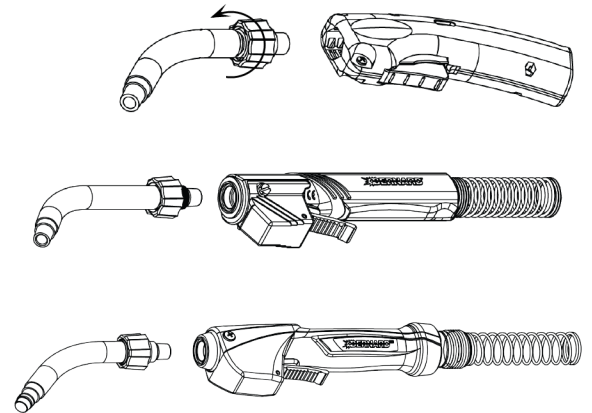

Figure 8-G

B. Changing the Neck - Fixed with Curved Handle

1. To remove neck, remove the nut insulator.
2. Using a wrench, rotate brass nut counterclockwise. Rotation will free neck from end fitting.
3. To install the neck, perform the above instructions in reverse order and tighten lock nut to 16 ft-lbs (21.7 Nm). Be sure nut insulator is in place.
4. Liner may need to be changed if switching to a neck of a different bend angle or length.



Figure 8-H

C. Changing the Neck - Fixed with T Series Straight Handle

1. Place neck in vise. Remove both switch housing mounting screws with an 8 mm nut driver.
2. Slide handle back, exposing the cable connection. Loosen the cable/neck connection using a 7/8" wrench.
3. Remove from vise and unthread neck by hand.
4. Thread the neck into the cable connection (hand tighten). Place neck in vise and tighten with a wrench to within 1/8" (3.2 mm) spacing between cable connection and neck.
5. Install the switch and reposition handle and switch housing.
6. Reinstall switch housing mounting screws.
7. Liner may need to be changed if switching to a neck of a different bend angle or length.

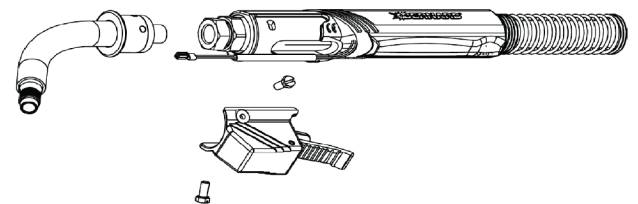
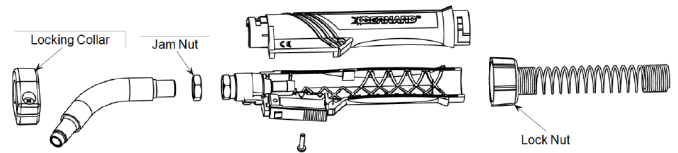

Figure 8-I

D. Changing the Neck - Fixed with T Series Small Straight Handle

Figure 8-J

1. Loosen and remove locking collar.
2. Place neck in vise, twist handle lock nut counterclockwise and pull away from handle.
3. Remove screw from handle.
4. Separate handle halves exposing jam nut and front of uncable.
5. Loosen jam nut using two 19 mm wrenches and unthread neck.
6. Remove from vise and unthread neck by hand.
7. Thread jam nut onto new neck.
8. Thread neck into uncable to desired orientation. Place neck in vise, tighten uncable and jam nut.
9. Reposition switch and handle.
10. Reinstall handle lock nut, locking collar and screw.
11. Liner may need to be changed if switching to a neck of different bend angle or length.



E. Changing the Neck - Fixed with C Series Straight Handle

Figure 8-K

1. Place neck in vise. Remove both switch housing mounting screws with a Phillips screwdriver.
2. Remove both the top and bottom pods from handle.
3. Slide handle back, exposing the cable connection. Loosen the cable/neck connection using a 7/8" wrench.
4. Remove from vise and unthread neck by hand.
5. Thread the new neck into the cable connection (hand tighten).
6. Place neck in vise and tighten with a wrench to within 1/8" (3.2 mm) spacing between the cable connection and neck.
7. Install the switch and reposition handle and switch housing.
8. Reinstall switch housing mounting screws.
9. Liner may need to be changed if switching to a neck of a different bend angle or length.

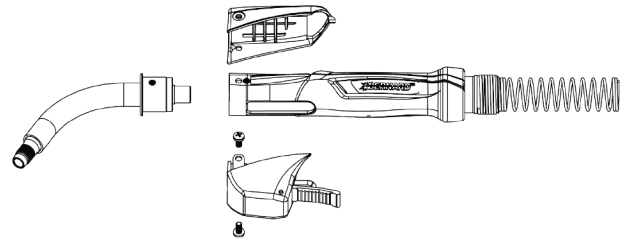

8-5 Changing the Handle and Switch



A. B Series Regular and Small Curved Handle

Figure 8-L

1. Remove screws and post fasteners from handles.
2. Separate handle halves and remove trigger.
3. Remove switch lead connectors with needle nose pliers.
4. To replace trigger, connect switch lead connectors onto terminals of new switch. Position handle half and trigger on cable so trigger leads are not pinched and movement of the trigger is not impaired.
5. Position the remaining handle half in place.
6. Reinstall post fasteners and screws. Torque to 10 in-lbs (1.1 Nm).

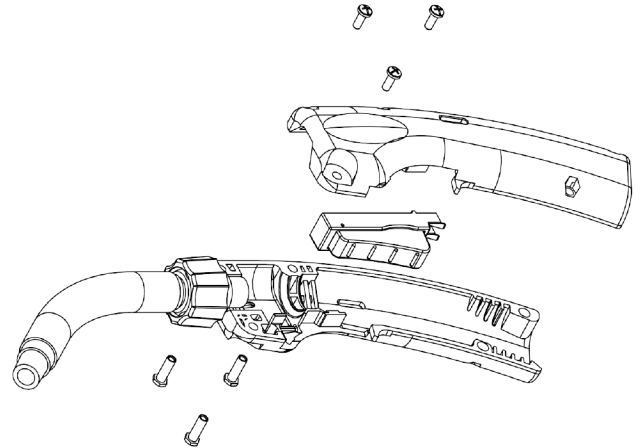

B. O Series Regular and Small Curved Handle

Figure 8-M

1. Loosen screws, but do not fully remove.
2. Pry open bottom side of handle halves with a flat blade screwdriver. Trigger should be able to be removed.
3. To replace trigger, install into handle halves with pivot posts inserted into handle cavities so movement is not impaired.
4. Tighten screws. Torque to 10 in-lbs (1.1 Nm).

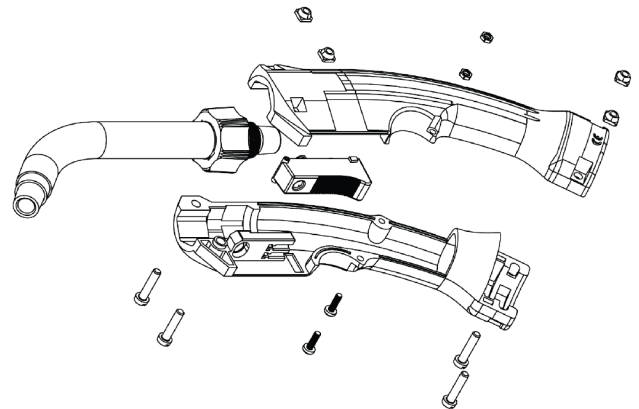

C. T Series Small Straight Handle

Figure 8-N

1. Loosen and remove locking collar.
2. Twist handle lock nut counterclockwise. Slide handle lock nut away from handle.
3. Remove screw from handle and separate handle halves.
4. Remove switch from switch lead connectors with needle nose pliers.
5. Connect switch lead connectors firmly onto new switch terminals with needle nose pliers.
6. Place gun assembly into handle half, positioning neck in desired position.
7. Fit switch into switch nest on handle (switch lead must lay parallel).
8. Reinstall second handle half.
9. Reinstall handle lock nut and locking collar on handle.
10. Insert screw and tighten.

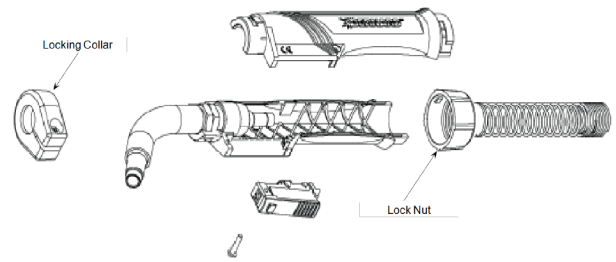

D. T Series Straight Handle (Switch Only)

Figure 8-O

1. Remove both housing screws with an 8 mm nut driver.
2. Ease switch out of switch housing with needle nose pliers to grip switch.
3. Remove switch from switch lead connectors with needle nose pliers.
4. Push switch lead connectors firmly onto new switch terminals with needle nose pliers.
5. Depress switch housing into nest on handle (switch leads must lay parallel).
6. Align housing holes with threaded holes in body and insert mounting screws first before tightening with 8 mm nut driver to even alignment.

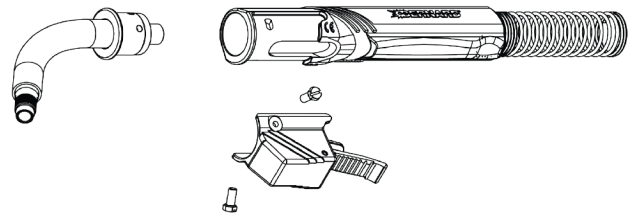

E. C Series Straight Handle (Switch Only)

Figure 8-P

1. Remove both switch mounting screws with a Phillips screwdriver.
2. Remove both the top and bottom pods from the handle.
3. Ease switch out of switch housing with needle nose pliers.
4. Remove switch from switch lead connectors with needle nose pliers.
5. Push lead connectors onto new switch using needle nose pliers.
6. Depress switch housing into nest on handle (switch leads must lay parallel).
7. Align the holes of body housing with the holes in the handle to start screws by hand. Finish tightening with a Phillips screwdriver.

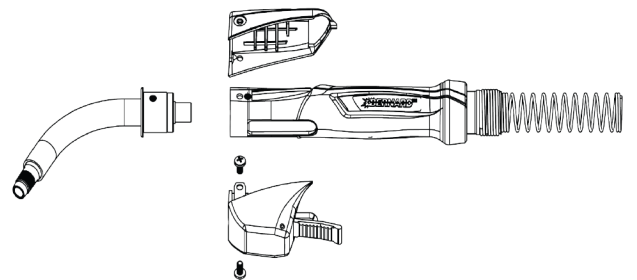

8-6 Changing the Power Pin



A. Universal Power Pin

1. Remove the liner by following steps listed in section 1-1 Changing the Liner on page 1.
2. Use wrenches and rotate power pin in a counterclockwise direction to remove it from the adaptor block.
3. Thread new power pin into adaptor block and use wrenches in a clockwise direction to thread power pin into adaptor block. Torque to 18 ft-lbs (24 Nm).
4. Reinstall liner by following the steps listed in section 1-1 Changing the Liner on page 1.

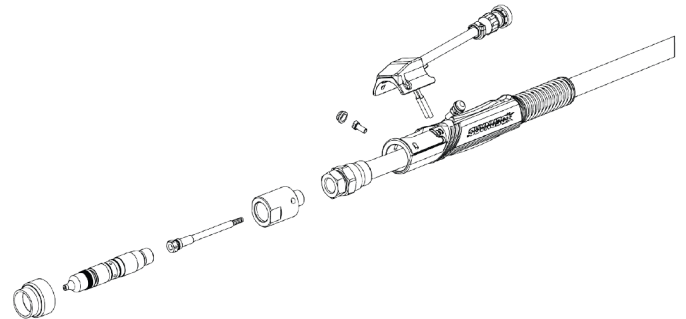

Figure 8-Q

B. Euro Power Pin

1. Remove liner, strain relief cap/spring, strain relief top half, screw cover and the screw that attaches the strain relief to the Euro block.
2. Slide strain relief bottom toward cable, exposing Euro block.
3. Remove Euro block from end fitting using appropriate wrenches in a counterclockwise rotation.
4. Disconnect the Euro block control leads from the gun by cutting as close as possible on both sides of the butt connectors to preserve wire length for later re-termination.
5. Remove adaptor nut and install onto new Euro block.
6. Assemble Euro block onto end fitting in a clockwise rotation using appropriate wrenches. Torque to 18 ft-lbs (24 Nm). Adaptor nut should rotate freely.
7. Strip the cable control leads 1/4" (6.5 mm) and re-terminate with appropriate butt connectors.
8. Align strain relief bottom with threaded hole in Euro block and install screw, assemble strain relief and liner.

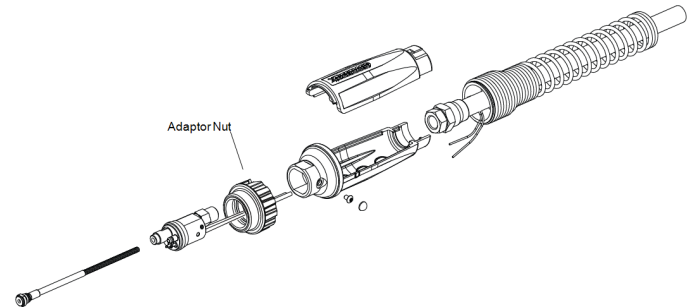
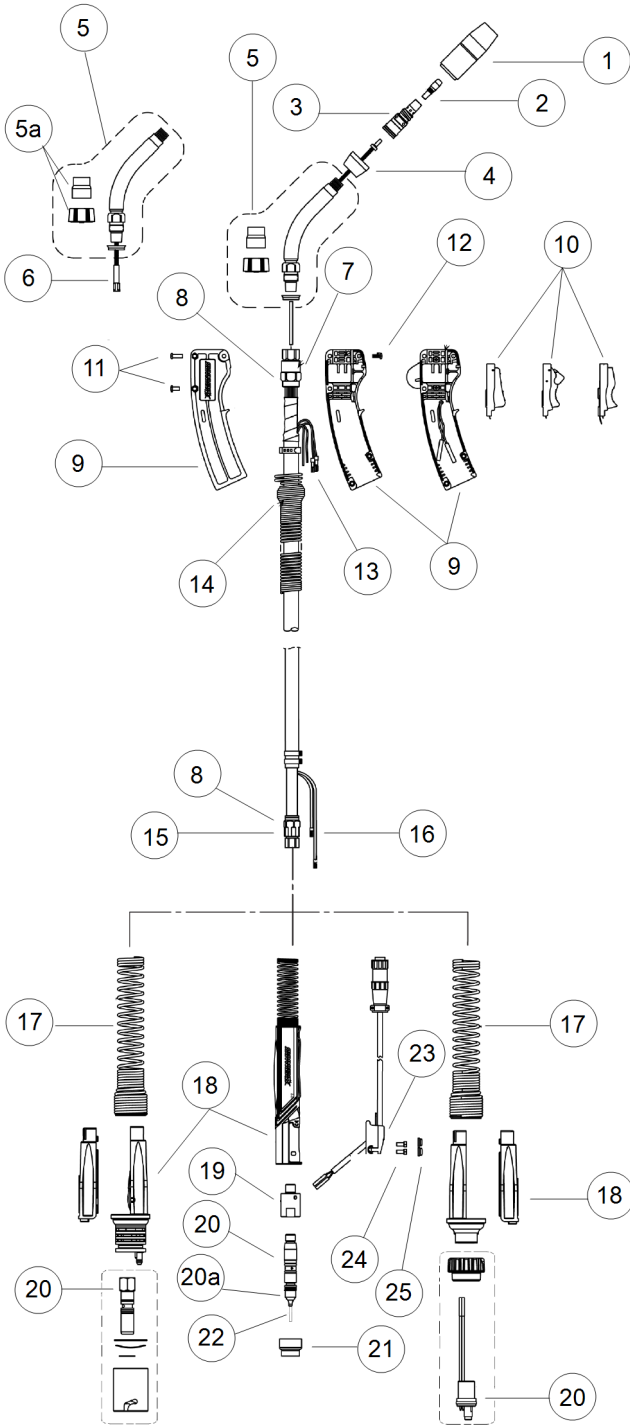

Figure 8-R

SECTION 9 — PARTS LIST

9-1 B Series Regular and Small Curved Handles with Yellow Trigger



Note: ** Diffusers are for AccuLock™ S With Rear Loading Liner, *RSR: Rear Strain Relief

ITEM	PART #			DESCRIPTION
	Q20	Q30	Q40	
1	401-5-62	401-6-62		Nozzle, TOUGH LOCK® HD
	NS-1218B	N-5818C		Nozzle, Centerfire™
	NS-A1218B	NS-A5818C	N-A5818C	Nozzle, AccuLock™ S
2	See SP-BTB			Contact Tip
3	404-26			Gas Diffuser, TOUGH LOCK® HD
	DS-1		D-1	Gas Diffuser, Centerfire™
	DS-A1/A1-C**		D-A1/A1-C**	Gas Diffuser, AccuLock™ S
4	See SP-BTB			Neck Insulator
5	See SP-BTB			Neck
5a	1840057			Q-Nut cover kit
6	See SP-BTB			Jump Liner
7	4213B	4313B	1680086	End Fitting, Front
8	4305	1540003		Cone Nut
NS	4939			Jacket Clamp
NS	4992P			Conduit Clamp
9	1880155		1880198	Handle Kit, Std, locking & dual pull trigger
	N/A		DSA-1	Handle Kit, DS std and locking trigger
10	5662			Trigger, Standard
	5662L			Trigger, Locking
	2690001			Trigger, Dual Pull, 3 wire
11	4207			Post Fastener
	2030004		N/A	Post Fastener, Short
	4209			Handle Screw (5 req'd)
12	2660001			Terminal, Quick Disconnect
13	2520074	2520042		Handle Spring
14	1680087	1680088		End Fitting, Rear
15	412-1			Switch Connector (4 req'd)
16	2520033	2520041		Spring, Strain Relief
17	410			Straight Rear Strain Relief
	2520069			Clamshell RSR* (Euro)
	2520073			Clamshell RSR* (Bernard® Power Pin)
18	414-400			Adaptor Block
19	See SP-BTB			Power Pin
20	See SP-BTB			Power Pin Cap
20a	See SP-BTB			Power Pin Insulator
21	See SP-BTB			Liner
22	1810053			Terminal Housing
23	1810054			Terminal Housing, DS
	411-3M			Screw, Trigger Housing
24	1620004			Screw Cover, Rear Pod

9-2 O Series Small Curved Handle with Blue Trigger

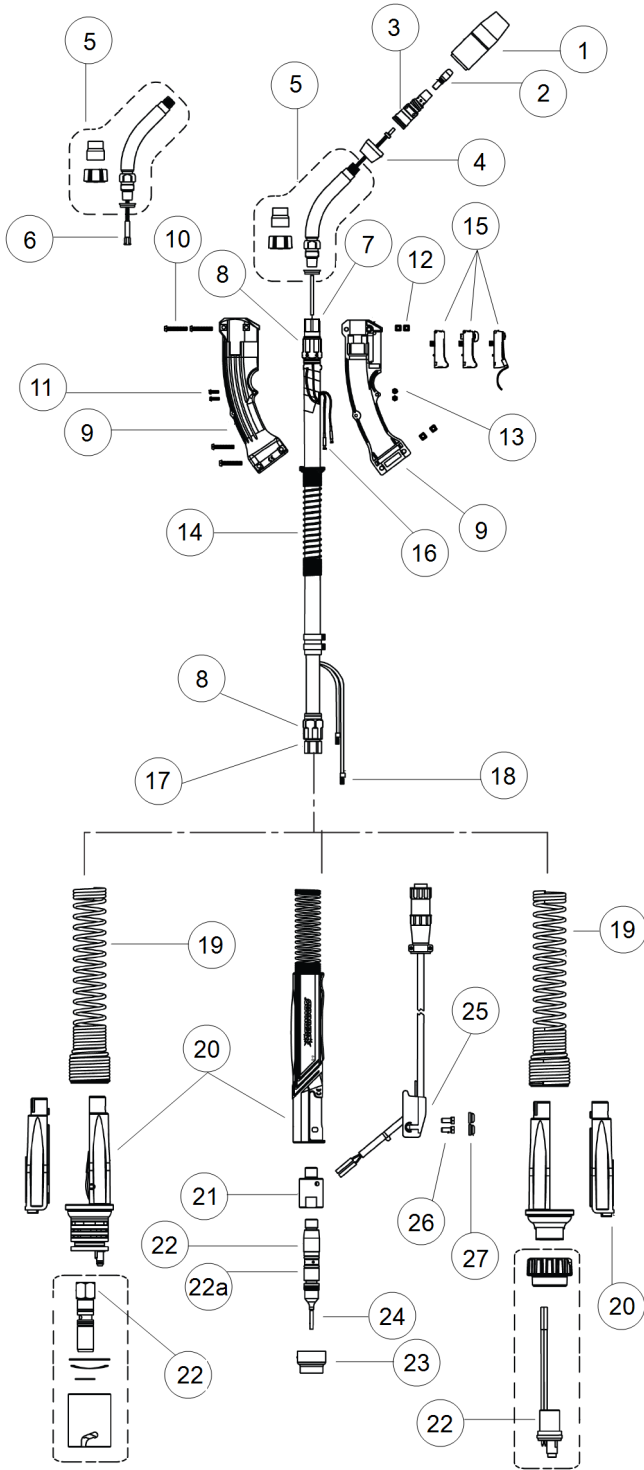

Note: ** Diffusers are for AccuLock™ S With Rear Loading Liner, *RSR: Rear Strain Relief

ITEM	PART #			DESCRIPTION
	Q20	Q30*/S30*	Q40*/S40*	
1		401-6-62		Nozzle, TOUGH LOCK® HD
	NS-1218B	NS-5818C	N-5818C	Nozzle, Centerfire™
	NS-A1218B	NS-A5818C	N-A5818C	Nozzle, AccuLock™ S
2	See SP-BTB			Contact Tip
3	404-26			Retaining Head, TL® HD
	DS-1		D-1	Gas Diffuser, Centerfire™
	DS-A1/A1-C**		D-A1/A1-C**	Gas Diffuser, AccuLock™ S
4	See SP-BTB			Neck Insulator
5	See SP-BTB			Neck
6	See SP-BTB			Jump Liner
7	4213B	4313B*	1680086*	End Fitting, Front
		1680064*	1680064*	
8	4305	1540003*	1540003*	Cone Nut
		1540007*	1540008*	
NS	4992	4992*	4992*	Conduit Clamp (2 req'd)
		N/A*	N/A*	
NS	4939			Jacket Clamp
9	1880219			Handle Kit, Standard and Locking
10	203296-005			Handle Screw, Large (4 req'd)
11	2280044			Handle Screw, Small (2 req'd)
12	177272H			Handle Nut (4 req'd)
13	2030029			Handle Nut, Small (2 req'd)
14	M169700-12	M169700-12*	M169700-12*	Handle Spring
		N/A*	N/A*	
15	177488H			Trigger, Standard
	177379			Trigger, Standard with Extension
	MS2110			Trigger, Locking
16	177271H			Trigger Pin (2 req'd)
17	1680087	1680087*	1680088*	End Fitting, Rear
		1680090*	1680090*	
18	412-1			Switch Connector
19	2520023	2520023*	2520041*	Spring, Strain Relief
		2520056*	2520056*	
20	410			Straight Rear Strain Relief
	2520069			Clamshell RSR* (Euro Power Pin)
	2520073			Clamshell RSR* (Bernard® Power Pin)
21	414-400			Adaptor Block
22	See SP-BTB			Power Pin
23	See SP-BTB			Power Pin Insulator
24	See SP-BTB			Liner
23	1810053			Terminal Housing
	1810054			Terminal Housing, Dual Schedule
24	411-3M			Screw, Trigger Housing
25	1620004			Screw Cover, Rear Pod
26	411-3MP			Screw, Rear Housing
27	1620004P			Screw Cover, Rear Housing

9-3 O Series Curved Handle with Blue Trigger

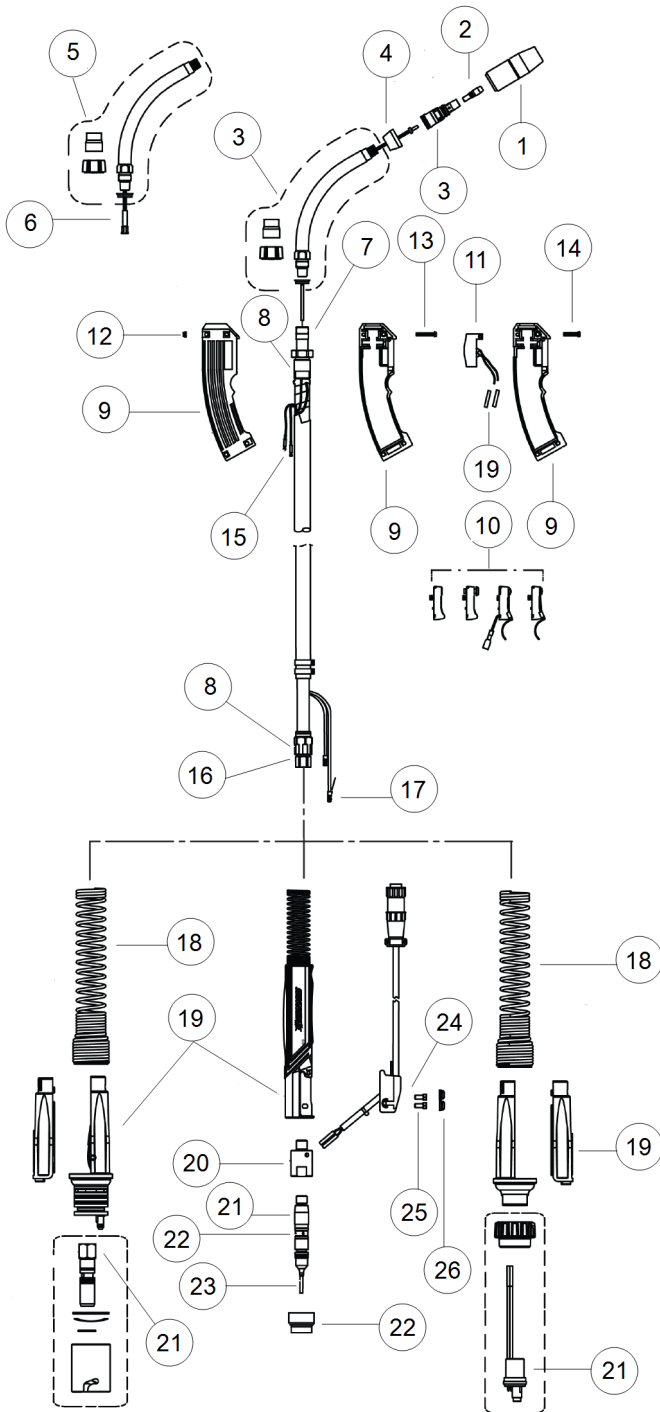

Note: ** Diffusers are for AccuLock™ S With Rear Loading Liner

ITEM	PART #			DESCRIPTION
	Q40*/S40*	Q50*/S50*	Q60*/S60*	
1	401-6-62	401-5-62	401-5-75	Nozzle, TOUGH LOCK® HD
	N-5818C	N-5814C	N-3414C	Nozzle, Centerfire™
	N-A5818C	N-A5814C	N-A3414C	Nozzle, AccuLock™ S
2	See SP-BTB			Contact Tip
3	404-26			Retaining Head, TOUGH LOCK® HD
	D-1			Gas Diffuser, Centerfire™
	D-A1/A1-C**			Gas Diffuser, AccuLock™ S
4	See SP-BTB			Neck Insulator
5	See SP-BTB			Neck
6	See SP-BTB			Jump Liner
7	1680049*	1680050*	1680050*	End Fitting
	1680065*	1680066*	1680066*	
8	1540003*	1540004*	1540004*	Cone Nut
	CB9201*	20038*	CB9206*	
NS	4992*	4993*	4993*	Conduit Clamp (2 req'd)
	N/A*	N/A*	N/A*	
NS	4939*	4944*	4944*	Jacket Clamp
	407709-013*	407709-013*	407709-013*	
9	1880220			Handle Kit, Standard, Locking and Dual Pull Trigger
	1880221			
10	177488H			Trigger, Standard
	MS2110			Trigger, Locking
	2620062			Trigger, Dual Pull w/ Extension
	177379			Trigger, Standard w/ Extension
11	PDS			Switch, D/S
12	177272H			Handle Nut
13	203296-005			Screw
14	20005			Screw, Modified (1 req'd D/S)
15	177271H			Trigger Pin (2 req'd)
16	1680088*	1680089*	1680089*	End Fitting, Rear
	1680090*	1680091*	1680091*	
17	412-1			Switch Connector (4 req'd)
18	N/A*	N/A*	2520041*	Spring, Strain Relief
	N/A*	N/A*	2520056*	
19	410			Straight Rear Strain Relief
	2520073			Clamshell Rear Strain Relief (Bernard Power® Power Pin)
	2520069			Clamshell Rear Strain Relief (Euro Power Pin)
20	414-400			Adaptor Block
21	See SP-BTB			Power Pin
22	See SP-BTB			Power Pin Insulator
23	See SP-BTB			Liner
24	1810053			Terminal Housing
	1810054			Terminal Housing, Dual Schedule
25	411-3M			Screw, Trigger Housing
26	1620004			Screw Cover, Rear Pod

9-4 T Series Small Straight Handle with Black Trigger

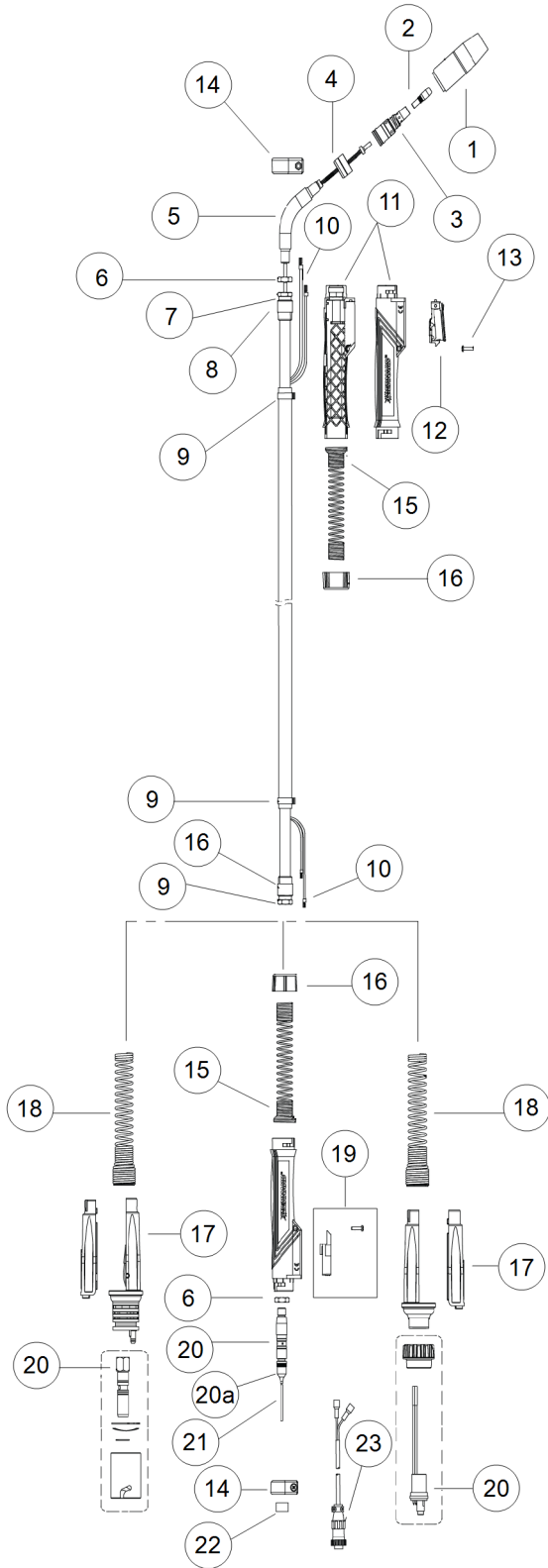

ITEM	PART #	DESCRIPTION
	Q20 / Q30	
1	401-6-62	Nozzle, TOUGH LOCK® Heavy Duty
	NS-5818C	Nozzle, Centerfire™
	NS-A5818C	Nozzle, AccuLock™ S
2	See SP-BTB	Contact Tip
3	404-26	Retaining Head, TOUGH LOCK® HD
	DS-1	Gas Diffuser, Centerfire™
	DS-A1/A1-C**	Gas Diffuser, AccuLock™ S
4	See SP-BTB	Neck Insulator
5	See SP-BTB	Neck
6	1960011	Jam Nut
7	318	End Fitting
8	319	Cone Nut
9	4939	Jacket Clamp
NS	4992	Conduit Clamp
10	412-1	Switch Connector (4 req'd)
NS	1880262	Cable Repair Kit (includes (1) #7, (1) #8, (1) #9, (1) Conduit Clamp, (2) #10)
11	320	Handle Kit (includes (1) #13, (1) #14)
12	211-5	Trigger Assembly
13	310-1-6	Screw, Handle
14	320-6	Handle Collar
15	M169700-12	Spring, Handle
16	320-3	Handle Cap, Locking, Rear
17	2520073	Clamshell Rear Strain Relief with installed gas pin (Bernard® Power Pin)
	2520069	Clamshell Rear Strain Relief (Euro Power Pin)
18	2520033	Spring Strain Relief
19	216-1	Control Plug Block
20	See SP-BTB	Power Pin
21	See SP-BTB	Liner
22	See SP-BTB	Power Pin Insulator
23	See SP-BTB	Trigger Control Plug Assembly

Note: ** Diffusers are for AccuLock™ S With Rear Loading Liner

9-5 T Series Straight Handle with Silver Trigger

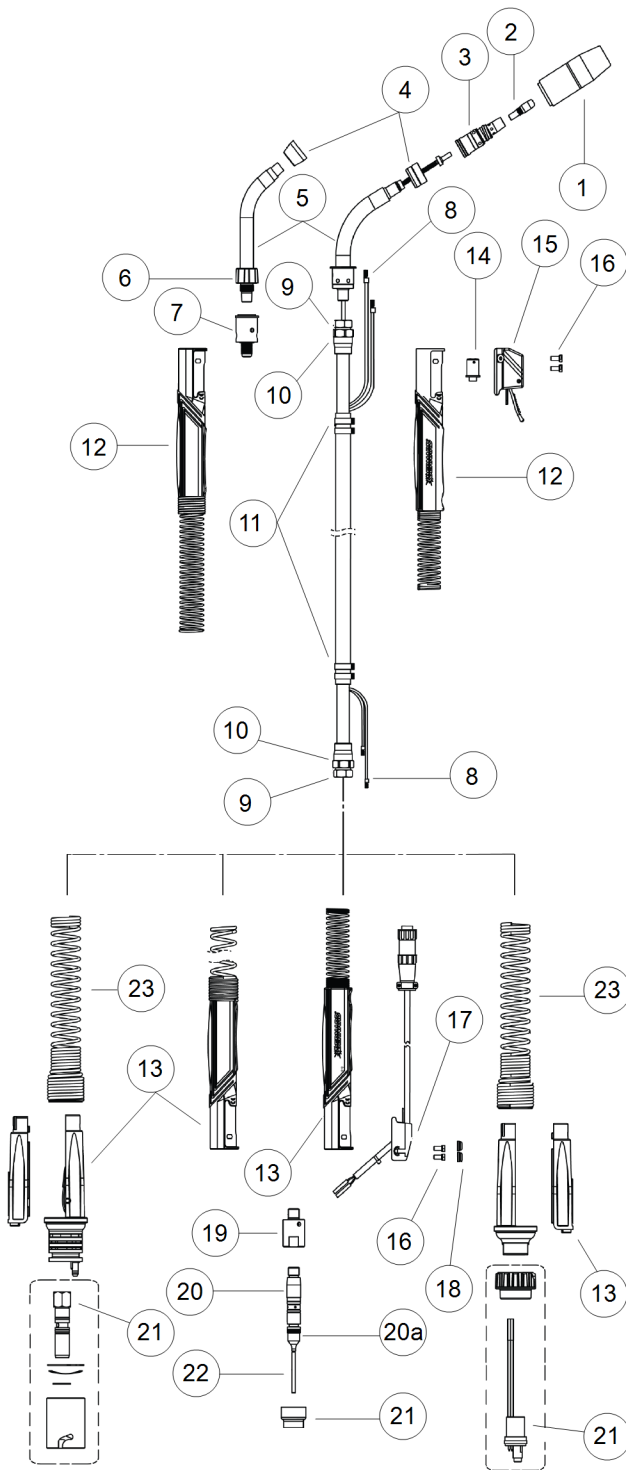

ITEM	PART #				DESCRIPTION
	Q30*/S30*	Q40*/S40*	Q50*/S50*	Q60*/S60*	
1	401-6-62		401-5-62	401-5-75	Nozzle, TOUGH [®] LOCK HD
	NS-5818C	N-5818C	N-5814C	N-3414C	Nozzle, Centerfire™
	NS-A5818C	N-A5818C	N-A5814C	N-A3414C	Nozzle, AccuLock™ S
2	See SP-BTB				Contact Tip
3	404-26				Retaining Head, TOUGH LOCK [®] HD
	DS-1	D-1			Diffuser, Centerfire
	DS-A1/-C**	D-A1/-C**			Diffuser, AccuLock™ S
4	See SP-BTB				Neck Insulator
5	See SP-BTB				Neck
6	1840057				Rotatable Nut Cover
7	1680085				Rotatable Neck Adaptor
8	412-1				Switch Connector
9	1680087*	1680088*	1680089*	1680089*	End Fitting
	1680090*	1680090*			
10	4305*	1540003*	1540004*	1540004*	Cone Nut
	CB9200*	CB9201*			
11	4939*	4939*	4944*	4944*	Jacket Clamp
	407709-013*	407709-013*	4944*	4944*	
NS	4992*	4992*	4993*	4993*	Conduit Clamp
	N/A*	N/A*	4993*	4993*	
NS	1880261*	1880263*	513-8*	513-8*	Cable Repair Kit
	N/A*	N/A*	513-8*	513-8*	
12	410			610	Handle
	410			616	Rear Strain Relief
13	2520073				Clamshell Rear Strain Relief (Bernard [®] Power Pin)
	2520069				Clamshell RSR* (Euro Power Pin)
14	411-1				Switch
15	411-2				Trigger, Standard
	411-4				Trigger, Locking
	411-11				Trigger, Dual Pull
	411-12				Trigger, D/S
	411-13				Trigger, D/S Locking
	411-3M				Screw, Trigger
16	1810053				Trigger Control Plug Terminal
	1810054				Trigger Control Plug Terminal, D/S
17	1620004				Screw Cover, Rear Housing
18	414-400				Adaptor Block
19	See SP-BTB				Power Pin
20	See SP-BTB				Power Pin Insulator
21	See SP-BTB				Liner
23	2520041*	2520041*	2520041*	2520041*	Spring, Strain Relief
	2520056*	2520056*	2520041*	2520041*	

Note: ** Diffusers are for AccuLock™ S With Rear Loading Liner, *RSR: Rear Strain Relief

9-6 C Series Straight Handle with Black Trigger

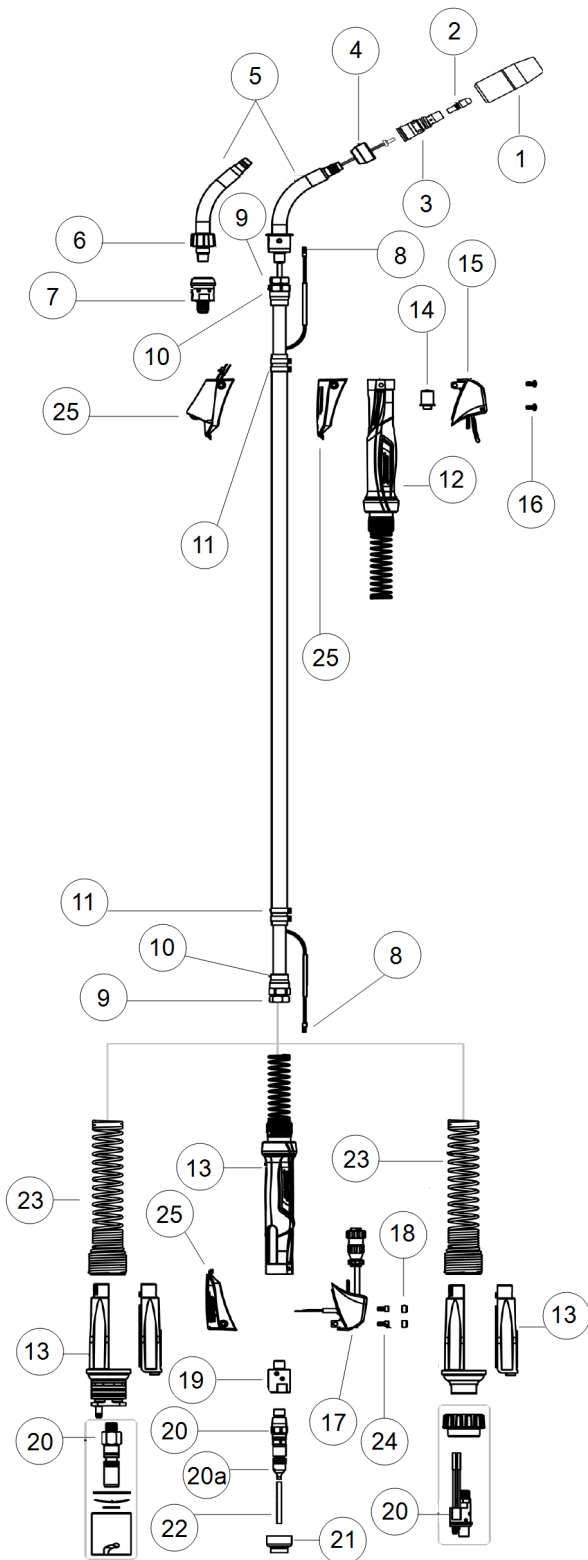

Note: ** Diffusers are for AccuLock™ S With Rear Loading Liner

ITEM	PART #				DESCRIPTION
	Q20	Q30*/S30*	Q40*/S40*	Q50	
1	401-6-62			401-5-62	Nozzle, TOUGH LOCK® HD
	NS-1218B	NS-5818C	N-5818C	N-5814C	Nozzles, Centerfire™
	NS-A1218B	NS-A5818C	N-A5818C	N-A5814C	Nozzle, AccuLock™ S
2	See SP-BTB				Contact Tip
3	404-26				Retaining Head, TL® HD
	DS-1		D-1		Diffuser, Centerfire™
	DS-A1/A1-C**		D-A1/A1-C**		Diffuser, AccuLock™ S
4	See SP-BTB				Neck Insulator
5	See SP-BTB				Neck
6	1840057				Rotatable Nut Cover
7	1680085C				Rotatable Neck Adaptor
8	412-1				Switch Connector
9	1680087*	1680087*	1680088*	1680089*	End Fitting
		1680090*	1680090*		
10	509°	4305*	1540003*	1540004*	Cone Nut
		CB9200*	CB9201*	509°	
11	4939*	4939*	4939*	4944*	Jacket Clamp
	4939°	407709-013°	407709-013°	4944°	
NS	4992*	4992*	4992*	4993*	Conduit Clamp
	4992°	N/A°	N/A°	4993°	
NS	1880261*	1880261*	1880263*	513-8*	Cable Repair Kit
	1880261°	N/A°	N/A°	513-8°	
12	1780086				Front Handle
13	1780086				Rear Strain Relief
	2520073				Clamshell Rear Strain Relief (Bernard® Power Pin)
	2520069				Clamshell Rear Strain Relief (Euro Pin)
14	411-1				Switch
15	2690077				Trigger, Standard
	1690088				Trigger, Dual Pull
16	2280064				Screw, Trigger Housing
	1810055				Trigger Control Plug
17	1810058				Trigger Control Plug, D/S
	1620006				Screw Cover, Rear Housing
18	414-400				Adaptor Block
19	See SP-BTB				Power Pin
20	See SP-BTB				Power Pin Insulator
21	See SP-BTB				Liner
23	2520041*	2520041*	2520041*	2520041*	Spring, Strain Relief
	2520041°	2520056°	2520056°	2520041°	
24	2280071				Screw, Rear Housing
25	1810046				Top Housing, Standard
	2690082				Top Housing, Insight Ltd
	2690083				Top Housing, D/S

SECTION 10 — CONSUMABLE PARTS

10-1 AccuLock™ S Consumable Series

A. Small AccuLock S Gas Diffusers and Nozzles

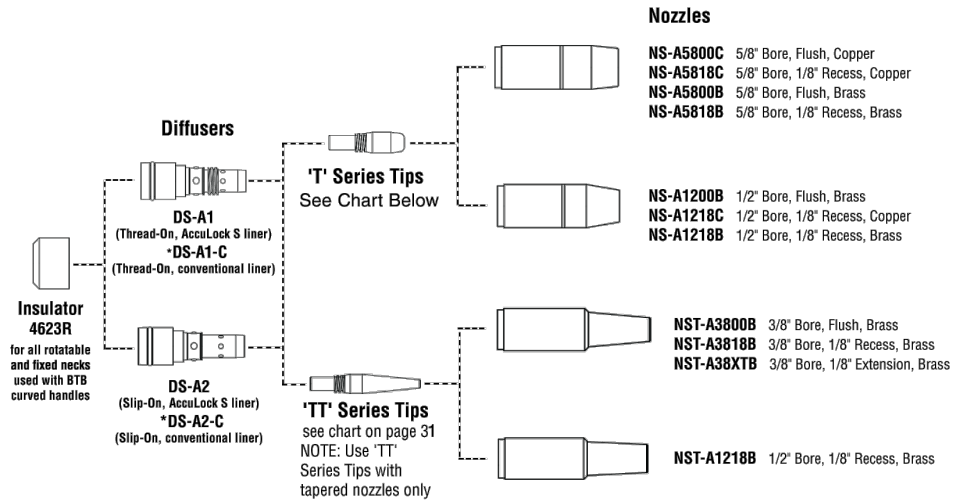

B. Large AccuLock S Gas Diffusers and Nozzles

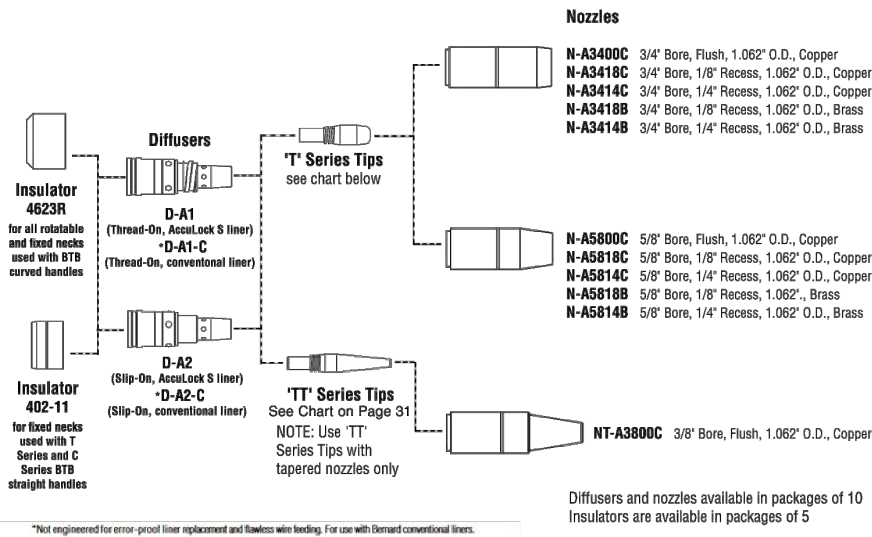

C. AccuLock Contact Tips

Contact Tips



T-A030CH	0.030" (0.8 mm)
T-A035CH	0.035" (0.9 mm)
T-A039CH	0.039" (1.0 mm)
T-A045CH	0.045" (1.2 mm)

T-A052CH	0.052" (1.4 mm)
T-A062CH	1/16" (1.6 mm)
T-A072CH	0.072" (1.8 mm)
T-A078CH	5/64" (2.0 mm)

T-A094CH	3/32" (2.4 mm)
T-A109CH	7/64" (2.8 mm)
T-A125CH	1/8" (3.2 mm)

Tapered Contact Tips



TT-A030CH	0.030" (0.8 mm)
TT-A035CH	0.035" (0.9 mm)

TT-A039CH	0.039" (1.0 mm)
TT-A045CH	0.045" (1.2 mm)

TT-A052CH	0.052" (1.4 mm)
TT-A062CH	1/16" (1.6 mm)

10-2 Centerfire™ Consumable Series

A. Small Centerfire Gas Diffusers and Nozzles

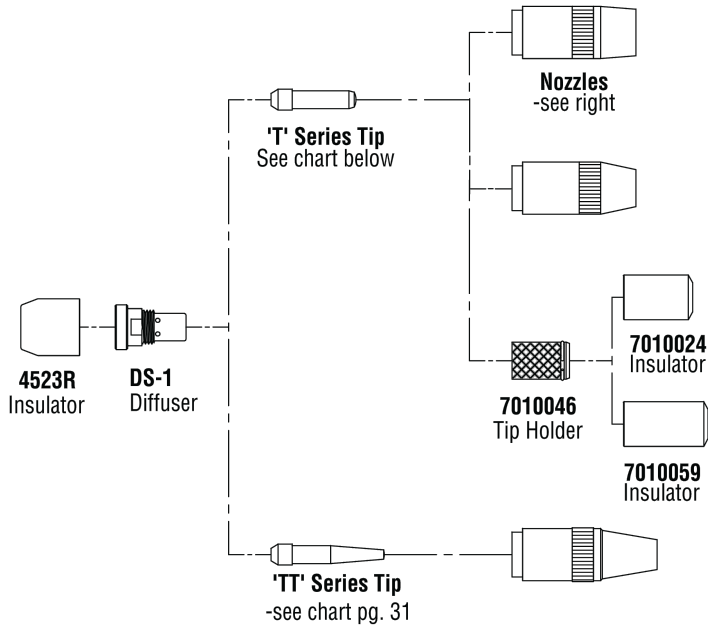

NS-5800C 5/8" Bore, Flush, .875" O.D., Copper
 NS-5818C 5/8" Bore, 1/8" Recess, .875" O.D., Copper
 NS-5800B 5/8" Bore, Flush, .875" O.D., Brass
 NS-5818C 5/8" Bore, 1/8" Recess, .875" O.D., Brass

NS-1218C 1/2" Bore, 1/8" Recess, .875" O.D., Copper
 NS-1200B 1/2" Bore, Flush, .875" O.D., Brass
 NS-1218B 1/2" Bore, 1/8" Recess, .875" O.D., Brass

NS-FLX Self Shielded Conversion Kit
 (Includes tip holder and both insulators)

NST-3800B 3/8" Bore, Flush, .875" O.D., Brass
 NST-3818B 3/8" Bore, 1/8" Recess, .875" O.D., Brass
 NST-38XTB 3/8" Bore, 1/8" Extension, .875" O.D., Brass

B. Large Centerfire Gas Diffusers and Nozzles

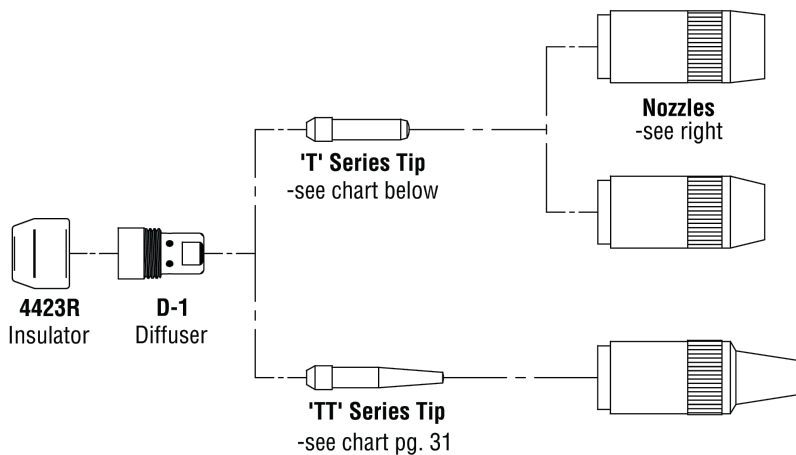

N-3400C 3/4" Bore, Flush, 1.063" O.D., Copper
 N-3418C 3/4" Bore, 1/8" Recess, 1.063" O.D., Copper
 N-3414C 3/4" Bore, 1/4" Recess, 1.063" O.D., Copper
 N-3418B 3/4" Bore, 1/8" Recess, 1.063" O.D., Brass
 N-3414B 3/4" Bore, 1/4" Recess, 1.063" O.D., Brass

N-5800C 5/8" Bore, Flush, 1.063" O.D., Copper
 N-5818C 5/8" Bore, 1/8" Recess, 1.063" O.D., Copper
 N-5814C 5/8" Bore, 1/4" Recess, 1.063" O.D., Copper
 N-5818B 5/8" Bore, 1/8" Recess, 1.063" O.D., Brass
 N-5814B 5/8" Bore, 1/4" Recess, 1.063" O.D., Brass

NT-3800C 3/8" Bore, Flush, 1.063" O.D., Copper

C. Centerfire Contact Tips

'T' Series Contact Tips

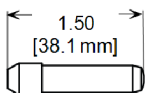

T-023	0.023" (0.6 mm)	T-045	0.045" (1.2 mm)	T-072	0.072" (1.8 mm)
T-030	0.030" (0.8 mm)	T-052	0.052" (1.4 mm)	T-078	5/64" (2.0 mm)
T-035	0.035" (0.9 mm)	T-062	1/16" (1.6 mm)	T-094	3/32" (2.4 mm)
T-039	0.039" (1.0 mm)				

'TT' Series Contact Tip

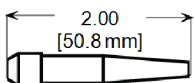

TT-030	0.030" (0.8 mm)	TT-039	0.039" (1.0 mm)	TT-052	0.052" (1.4 mm)
TT-035	0.035" (0.9 mm)	TT-045	0.045" (1.2 mm)	TT-062	1/16" (1.6 mm)

10-3 Centerfire HD Consumable Series

Centerfire HD Consumable Series is not configurable and will need to be ordered separately. Couple the Centerfire HD nozzle body with a Centerfire HD nozzle cone to form a complete Centerfire HD nozzle.

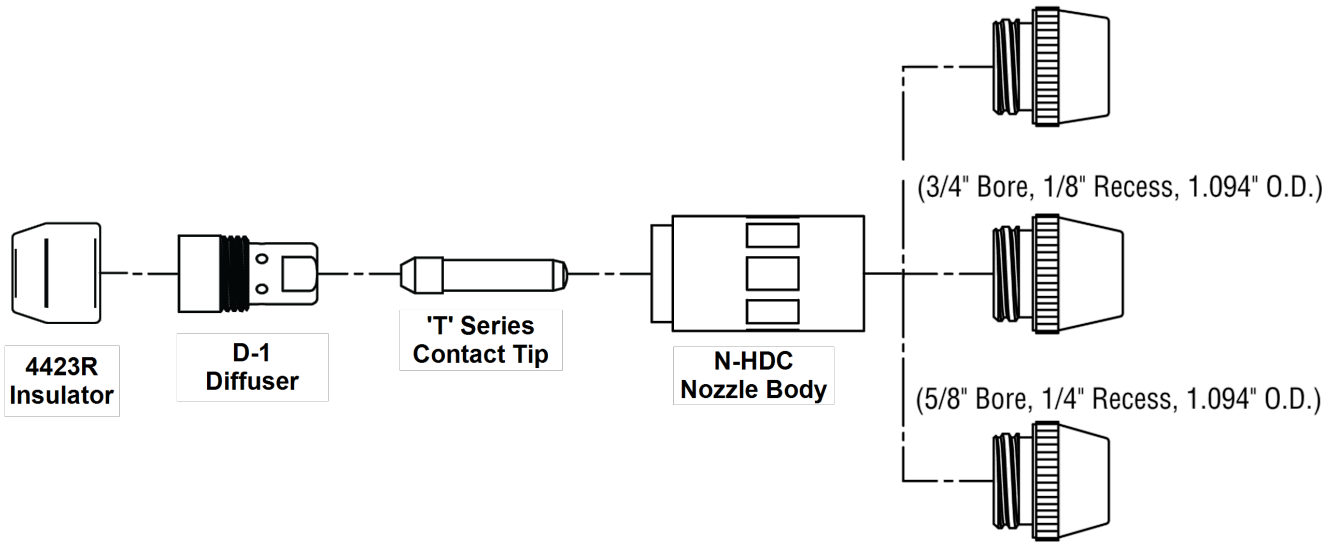

Diffusers, nozzle cones and bodies and contact tips are available in packages of 10 and insulators are available in packages of 5

(5/8" Bore, 1/8" Recess, 1.094" O.D.)

10-4 TOUGH LOCK® Consumable Series

A. TOUGH LOCK Contact Tip Part Numbers

WIRE SIZE	STANDARD DUTY	HEAVY DUTY	HEAVY DUTY TAPERED	EXTENDED LIFE HEAVY DUTY	EXTRA HEAVY DUTY	QTY
0.023" (0.6 mm)	403-14-23	N/A	N/A	N/A	N/A	100
0.030" (0.8 mm)	403-14-30	403-20-30	403-21-30	403-27-30	N/A	100
0.035" (0.9 mm)	403-14-35	403-20-35	403-21-35	403-27-35	N/A	100
0.039" (1.0 mm)	N/A	403-20-1.0	403-21-1.0	403-27-1.0	603-20-1.0	100
0.045" (1.2 mm)	403-14-45	403-20-45	403-21-45	403-27-45	603-20-45	100
3/64" (1.2 mm)	N/A	403-20-364	N/A	403-27-364	603-20-364	100
0.052" (1.3 mm)	N/A	403-20-52	N/A	403-27-52	603-20-52	100
0.055" (1.4 mm)	N/A	403-20-1.4	N/A	N/A	603-20-1.4	100
1/16" (1.6 mm)	N/A	403-20-116	N/A	403-27-116	603-20-116	100
0.070" (1.8 mm)	N/A	403-20-1.8	N/A	N/A	N/A	100
0.078" (2.0 mm)	N/A	403-20-78	N/A	N/A	N/A	100
5/64" (2.0 mm)	N/A	403-20-564	N/A	N/A	603-20-564	100
3/32" (2.4 mm)	N/A	403-20-332	N/A	N/A	603-20-332	100
7/64" (2.8 mm)	N/A	N/A	N/A	N/A	603-20-764	100
1/8" (3.2 mm)	N/A	N/A	N/A	N/A	603-20-18	100

B. TOUGH LOCK Retaining Head Part Numbers

DESCRIPTION	SINGLE TAPER PART NUMBER	DUAL TAPER PART NUMBER	QTY
Heavy Duty	404-20-25	404-26-25	25
Heavy Duty	404-20	404-26	100
Heavy Duty	404-20-250	404-26-250	250
Standard Duty	404-14-25	404-18-25	25
Standard Duty	404-14	404-18	100
THREAD-ON RETAINING HEADS FOR NEW STYLE THREAD-ON NOZZLES			
Heavy Duty	N/A	404-53-25	25

C. TOUGH LOCK Nozzle Part Numbers



A. BOTTLENECK

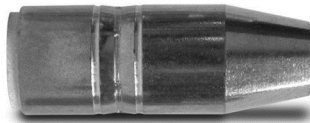

B. TAPER

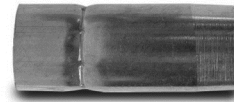

C. STRAIGHT

PART NUMBER	NOZZLE TYPE	BORE	TYPE	MATERIAL	O.D.	LENGTH	TIP POSITION	QTY
401-6-50	Heavy Duty	1/2"	B	Copper	1.062"	2.88"	1/8" Recess	10
401-48-62	Heavy Duty	5/8"	A	Copper	1.062"	2.76"	Flush	10
401-5-62	Heavy Duty	5/8"	B	Copper	1.062"	3.00"	1/4" Recess	10
401-6-62	Heavy Duty	5/8"	B	Copper	1.062"	2.88"	1/8" Recess	10
401-71-62	Heavy Duty	5/8"	B	Brass	1.106"	2.88"	1/8" Recess	10
401-7-62	Heavy Duty	5/8"	B	Brass	1.106"	3.00"	1/4" Recess	10
401-81-62	Heavy Duty	5/8"	B	Copper	1.062"	2.63"	1/8" Stick-Out	10
401-87-62	Heavy Duty	5/8"	B	Brass	1.062"	2.63"	1/8" Stick-Out	10
401-5-75	Heavy Duty	3/4"	B	Copper	1.062"	3.00"	1/4" Recess	10
401-6-75	Heavy Duty	3/4"	B	Copper	1.062"	2.88"	1/8" Recess	10
401-7-75	Heavy Duty	3/4"	B	Brass	1.106"	2.88"	1/8" Recess	10
401-42-50	Standard Duty	1/2"	A	Brass	0.938"	2.88"	1/8" Recess	10
401-4-50	Standard Duty	1/2"	B	Copper	0.938"	2.88"	1/8" Recess	10
401-44-50	Standard Duty	1/2"	A	Brass	0.938"	2.50"	1/4" Stick-Out	10
401-48-50	Standard Duty	1/2"	A	Brass	0.938"	2.63"	1/8" Recess	10
401-4-38	Standard Duty	3/8"	B	Copper	0.938"	2.74"	Flush	10
401-40-38	Standard Duty	3/8"	B	Brass	0.938"	2.81"	1/16" Recess	10
401-4-62	Standard Duty	5/8"	B	Copper	0.938"	2.88"	1/8" Recess	10
401-8-62	Standard Duty	5/8"	B	Copper	0.938"	2.63"	1/8" Stick-Out	10
401-9-62	Standard Duty	5/8"	B	Copper	0.938"	2.51"	1/4" Stick-Out	10

SECTION 11 — TROUBLESHOOTING

11-1 Troubleshooting Table

PROBLEM	POSSIBLE CAUSE	CORRECTIVE ACTION
1. Electrode does not feed.	<ol style="list-style-type: none"> 1. Feeder relay. 2. Broken control lead. 3. Poor adaptor connection. 4. Improper / worn drive roll. 5. Drive roll tension misadjusted. 6. Burn back to contact tip. 7. Wrong size liner. 8. Buildup inside of liner. 	<ol style="list-style-type: none"> 1. Consult feeder manufacturer. 2. a. Test and connect spare control lead. b. Install new cable. 3. Test and replace leads and/or contact pins. 4. Replace drive roll. 5. Adjust tension at feeder. 6. See 'Contact tip burn back'. 7. Replace with correct size. 8. Replace liner or clean out with compressed air, check condition of electrode.
2. Contact tip burn back.	<ol style="list-style-type: none"> 1. Improper voltage and/or wire feed speed. 2. Erratic wire feeding. 3. Improper tip stickout. 4. Improper electrode stickout. 5. Faulty ground. 	<ol style="list-style-type: none"> 1. Adjust parameters. 2. See 'Erratic wire feeding'. 3. Adjust nozzle / tip relationship. 4. Adjust wire stickout. 5. Replace cables and/or connections.
3. Tip disengages from the gas diffuser.	<ol style="list-style-type: none"> 1. Worn gas diffuser/retaining head. 2. Improper tip installation. 3. Extreme heat or duty cycle. 	<ol style="list-style-type: none"> 1. Replace tip and/or gas diffuser / retaining head. 2. Install as per section 1-1 Changing Consumables on page 1. 3. Replace with heavy duty consumables. See appropriate Spec Sheet for details.
4. Short contact tip life.	<ol style="list-style-type: none"> 1. Contact tip size 2. Electrode eroding contact tip. 3. Exceeding duty cycle. 	<ol style="list-style-type: none"> 1. Replace with proper size. 2. Inspect and/or change drive rolls. 3. Replace with properly rated Bernard MIG Gun.
5. Erratic arc.	<ol style="list-style-type: none"> 1. Worn contact tip. 2. Buildup inside of liner. 3. Wrong tip size. 4. Not enough bend in neck. 	<ol style="list-style-type: none"> 1. Replace contact tip. 2. Replace liner, check condition of electrode. 3. Replace with correct tip size. 4. Replace with 45° or 60° neck.
6. Erratic wire feeding.	<ol style="list-style-type: none"> 1. Buildup inside of liner. 2. Wrong size liner. 3. Improper drive roll size. 4. Worn drive roll. 5. Improper guide tube relationship. 6. Improper wire guide diameter. 7. Gaps at liner junctions. 8. Feeder malfunction. 9. Worn contact tip. 	<ol style="list-style-type: none"> 1. Replace liner, check condition of electrode. 2. Replace with new liner of proper size. 3. Replace with proper size drive roll. 4. a. Replace with new drive roll. b. Repair worn drive roll. 5. a. Adjust / replace guide as close to drive rolls as possible. b. Eliminate all gaps in electrode path. 6. Replace with proper guide diameter. 7. a. Replace with new liner trimmed as per section 1-1 Changing Consumables on page 1. b. Replace guide tube / liner trimming as close to mating component as possible. 8. Consult feeder manufacturer. 9. Inspect and replace.*
7. Extreme spatter.	<ol style="list-style-type: none"> 1. Improper machine parameters. 2. Improper tip installation. 3. Improper shielding gas coverage. 4. Contaminated wire or workpiece. 	<ol style="list-style-type: none"> 1. Adjust parameters. 2. Adjust nozzle / tip relationship. 3. a. Verify shielding gas coverage. b. Verify gas mixture. 4. Clean wire and workpiece.

<p>8. Porosity in weld.</p>	<ol style="list-style-type: none"> 1. Insulator worn. 2. Gas diffuser damaged 3. Extreme heat or duty cycle. 4. Solenoid faulty. 5. No gas. 6. Flow improperly set. 7. Gas ports plugged. 8. Ruptured gas hose. 9. Control circuit loss. 10. Worn, cut or missing o-rings. 11. Loose fittings. 12. AccuLock S power pin cap not torqued to the correct spec. 	<ol style="list-style-type: none"> 1. Replace nozzle / insulator. 2. Replace gas diffuser or o-rings. 3. Replace with heavy duty consumables. 4. Replace solenoid. 5. a. Install full tanks. b. Check supply. c. Check for hose leaks. 6. Adjust flow. 7. a. Clean or replace gas diffuser. b. Clean nozzle. 8. Repair or replace cable or line. 9. See 'Electrode does not feed'. 10. Replace o-rings. 11. Tighten gun and cable connections to specified torque. See Section 8 — Replacement on page 14. 12. Tighten power pin cap to specified torque. See section 1-1 Changing AccuLock™ S Consumables on page 1.
<p>9. Gun running hot.</p>	<ol style="list-style-type: none"> 1. Exceeding duty cycle. 2. Loose or poor power connection. 	<ol style="list-style-type: none"> 1. a. Replace with properly rated Bernard MIG Gun. b. Decrease parameters to within gun rating. 2. a. Clean, tighten or replace cable grounding connection. b. Tighten gun and cable connections to specified torque. See Section 8 — Replacement on page 14.
<p>10. Liner is discolored full length.</p>	<ol style="list-style-type: none"> 1. Short circuit to electrode. 2. Broken copper stranding in power cable. 	<ol style="list-style-type: none"> 1. Isolate electrode reel from feeder and drive block. Consult feeder manufacturer's manual. 2. Replace MIG gun.
<p>11. Sporadic feeding of aluminum electrode.</p>	<ol style="list-style-type: none"> 1. Tip galling. 2. Synthetic liner melting. 3. Wire deformed by feeder rolls. 	<ol style="list-style-type: none"> 1. Inspect and replace the contact tip.* 2. a. Replace liner. b. Replace with composite liner. c. Replace the neck and jump liner. 3. Adjust drive rolls as per feeder manufacturer's manual.

**In some cases with aluminum and mild steels, it may be necessary to use a contact tip with either a larger or smaller bore size.*

NOTES

ADDITIONAL SUPPORT MATERIALS

For additional support materials such as Spec Sheets, troubleshooting information, how-to guides and videos, animations, online configurators and much more, please visit Bernard. Scan the QR Code with your smart phone for immediate access to Tregaskiss.com/TechnicalSupport.



Scan to view the BTB MIG Gun Owner's Manual



Scan to view the BTB MIG Gun Spec Sheet



Scan to view the AccuLock™ S (Semi-Auto) Consumables Spec Sheet



Scan to view the Centerfire® Consumables Spec Sheet



Scan to view the TOUGH LOCK® Consumables Spec Sheet



Scan to view the QUICK LOAD® Liner and AutoLength™ Pins Spec Sheet



Bernard
A Division of Miller Electric Mfg. LLC
449 West Corning Road
Beecher, Illinois 60401 USA

Phone: 1-855-MIGWELD (644-9353) (US & Canada)
+1-519-737-3000 (International)

Fax: 1-708-946-6726

For more information, visit us at Tregaskiss.com

