

TECHNICAL GUIDE

TOUGH GUN ThruArm™
Series Robotic MIG Guns
for
KUKA KR 5 arc HW Robot

- **INSTALLATION**
- **MAINTENANCE**
- **TECHNICAL DATA**
- **OPTIONS**
- **EXPLODED VIEW & PARTS LIST**
- **ORDERING INFORMATION**

Effective September 2010 –
QUICK LOAD™ Liners Standard
on all TOUGH GUN™ Robotic MIG Guns

Certified ISO 9001 : 2008
Please read instructions prior to use.
Save this manual for future reference

TABLE OF CONTENTS

THANK YOU.....	2
GENERAL SAFETY INFORMATION.....	3
WARRANTY.....	3
1.0 – COMPLETE ASSEMBLY OVERVIEW.....	4
2.0 – INSTALLATION.....	5
STEP #1 - POSITIONING THE ROBOT.....	5
STEP #2 - REMOVING OUTER COVER.....	5
STEP #3 - INSTALLING GUN TO ROBOT.....	5
STEP #4 - CONNECTING LSR UNICABLE.....	6
STEP #5 - INSTALLING GOOSENECK.....	6
STEP #6 - INSTALLING POWER PIN TO THE LSR UNICABLE.....	7
STEP #7 - INSTALLING QUICK LOAD LINER.....	7
STEP #8 - INSTALLING CONSUMABLES.....	8
STEP #9 - INSTALLING GUN TO WIRE FEEDER.....	8
3.0 – MAINTENANCE.....	9
3.1 REPLACEMENT / ADJUSTMENT OF CLUTCH LIMIT SWITCH.....	9
3.2 REPLACEMENT OF EURO CONNECTION.....	9
3.3 REPLACEMENT OF QUICK LOAD™ LINER.....	10
4.0 – TECHNICAL DATA.....	11
4.1 GUN CONFIGURATIONS.....	11
4.2 CENTER OF MASS.....	11
4.3 AMPERAGE RATINGS*.....	12
5.0 – EXPLODED VIEW & PARTS LIST – K5800.....	12
6.0 – PARTS LISTS FOR K5800A, K5800W, & K5800AW MODELS.....	13
6.1 WIRE BRAKE FOR K5800W MODELS.....	13
6.2 AIR BLAST FOR K5800A & K5800AW MODELS.....	13
7.0 – ORDERING INFORMATION.....	14

THANK YOU...

...for selecting a Tregaskiss TOUGH GUN ThruArm™ Series Robotic MIG Gun. Manufacturing operations demand extremely dependable robotic equipment. With this in mind, the TOUGH GUN™ MIG Gun was designed and engineered to be a reliable tool to support high production within a robotic cell. As the name implies, the TOUGH GUN MIG Gun is made from durable materials and components engineered to perform in a rugged welding environment. Your TOUGH GUN MIG Gun is completely assembled and ready to weld, and has undergone numerous quality checks to ensure high performance.

The instructions and illustrations in this technical guide make it easy for you to maintain your TOUGH GUN MIG Gun. **Please read, understand, and follow all safety procedures.** Keep this Technical Guide booklet as a handy reference when ordering complete guns, parts and special options. **For technical support and special applications, please call the Tregaskiss Technical Service Department at 1-877-737-3111 or fax 1-877-737-2111.** Our trained technicians are available between 8:30 AM and 4:30 PM EST, and will answer your application or repair questions.

Tregaskiss employees build TOUGH GUN MIG Guns for the world's welding professionals. We are always striving to improve our products and services, and would appreciate receiving your suggestions or comments. Please contact us immediately if you experience any safety or operating problems.

GENERAL SAFETY INFORMATION

Before installation or operation of TOUGH GUN MIG Guns, please read the safety precautions listed below.

1. Do not touch live electrical parts. The following should be checked to prevent electrical shock:
 - Faulty or damaged equipment is repaired or replaced.
 - Equipment is off when not in use.
2. Ensure that all safety devices, guards, shields or barriers are properly in place and connected correctly before allowing operation of the equipment.
3. CSA Standard W117.2 CODE FOR SAFETY IN WELDING AND CUTTING obtainable from the Canadian Standards Association, Standards Sales, 178 Rexdale Boulevard, Rexdale, Ontario, Canada M9W 1R3.
ANSI Standard Z49.1 CODE FOR SAFETY IN WELDING AND CUTTING obtainable from the American National Standards Institute, 1430 Broadway, New York, NY 10018.

CALIFORNIA PROPOSITION 65 WARNING

This product, when used for welding or cutting, produces fumes or gases which contain chemicals known to the State of California to cause birth defects and, in some cases, cancer.

This product contains chemicals, including lead, known to the State of California to cause cancer, and birth defects or other reproductive harm. *Wash hands after use.*

(California Health & Safety Code Section 25249.5 at seq.)



WARRANTY

Product is warranted to be free from defects in material and workmanship for the period specified below after the sale by an authorized Buyer. Should there be a defect please refer to our Return Merchandise Policy.

PRODUCT	WARRANTY PERIOD
TOUGH GUN™ MIG Guns and Components	180 days
TGX™ Chassis and TGX™ Ready To Weld MIG Guns	90 days
TOUGH GUN™ Reamer	1 year
TOUGH GARD™ Spatter Cleaner	1 year
TOUGH GUN™ Robotic Peripherals (Clutch, Sprayer, Wire Cutter, Clutch Disc, Mounting Arms)	1 year
Low-Stress Robotic Unicables (LSR Unicables)	2 years

Tregaskiss reserves the right to repair, replace or refund the purchase price of non-conforming product. Product found not defective will be returned to the Buyer after notification by Customer Service.

Tregaskiss makes no other warranty of any kind, expressed or implied, including, but not limited to the warranties of merchantability or fitness for any purpose. Tregaskiss shall not be liable under any circumstances to Buyer, or to any person who shall purchase from Buyer, for damages of any kind including, but not limited to any, direct, indirect incidental or consequential damages or loss of production or loss of profits resulting from any cause whatsoever, including, but not limited to, any delay, act, error or omission of Tregaskiss.

Genuine Tregaskiss parts must be used for safety and performance reasons or the warranty becomes invalid. Warranty shall not apply if accident, abuse, or misuse damages a product, or if a product is modified in any way except by authorized Tregaskiss personnel.

1.0 - COMPLETE ASSEMBLY OVERVIEW

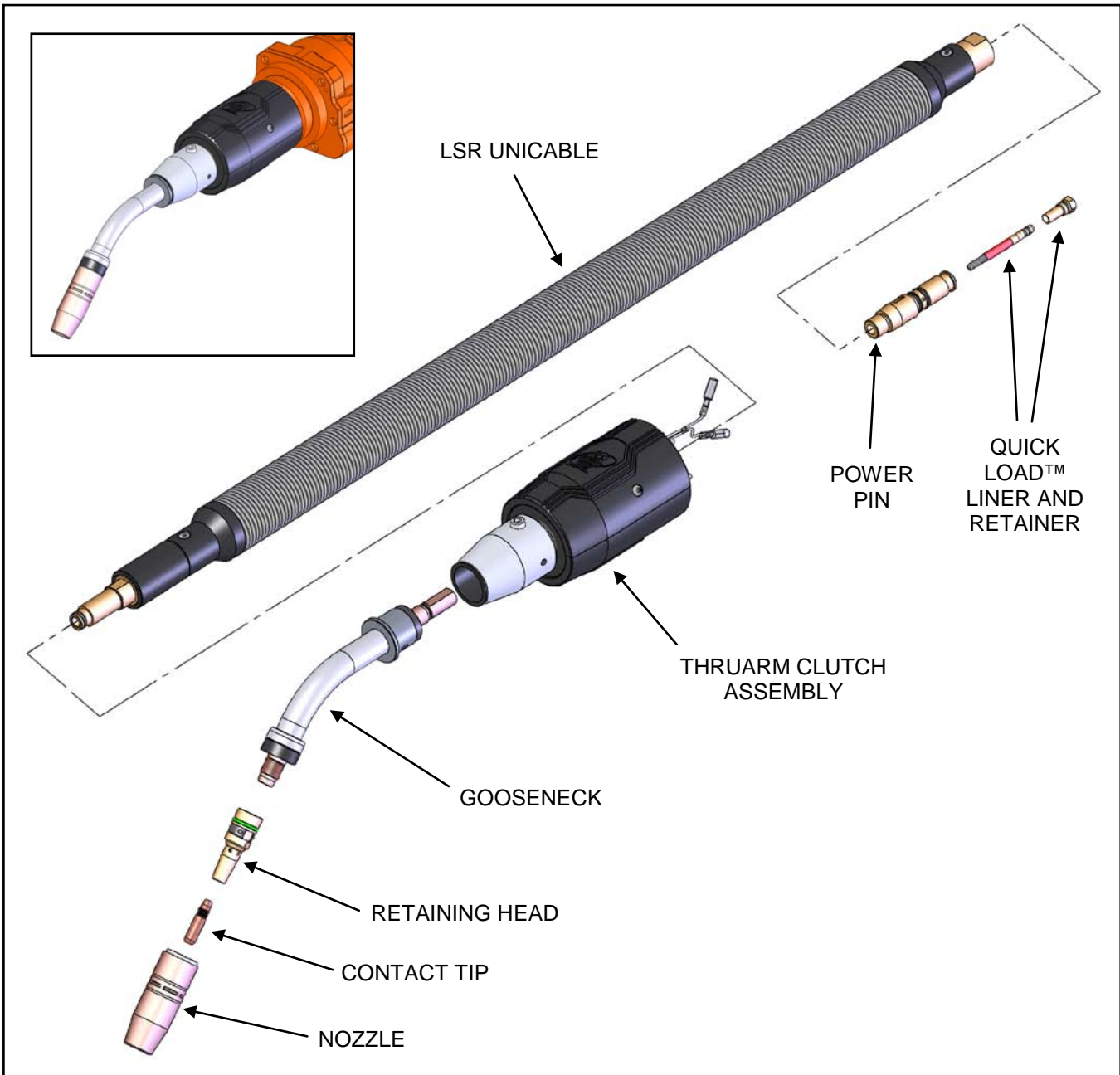

For part numbers, please see *Section 6.0 EXPLODED VIEW AND PARTS LIST.*

2.0 – INSTALLATION

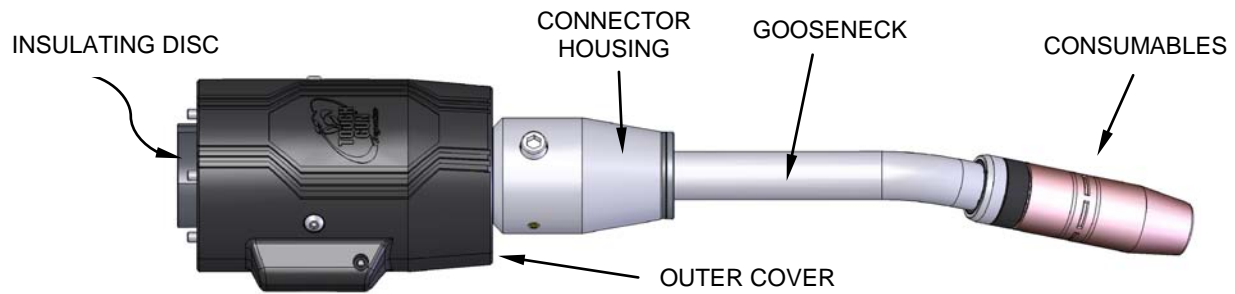

STEP #1 - POSITIONING THE ROBOT

- Position the robot with the wrist and top axis as shown to properly complete the gun installation.

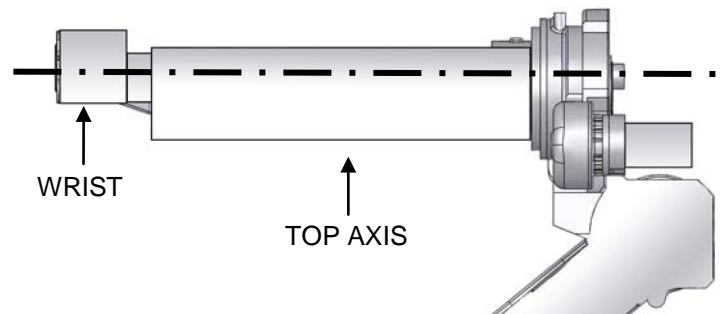

STEP #2 - REMOVING OUTER COVER

- Unthread (3) M4 SBHCS, using a 2.5 mm Allen key.
- Unthread (1) M3 SHCS, using a 2.5 mm Allen key and pull apart both cover halves.
- Insulating disc** should remain in place, located by dowel.

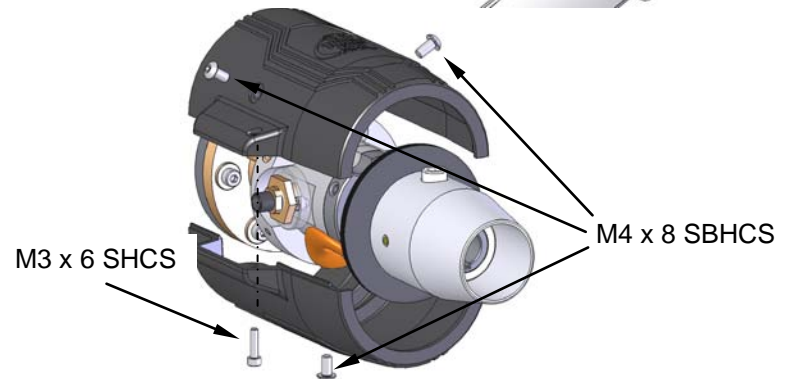

STEP #3 - INSTALLING GUN TO ROBOT

- Locate assembly onto robot mounting face using dowel pin as a guide.
- Insert M4x20 (x6) bolts through insulating disc and mounting flange into robot face. Thread bolts clockwise using a 3 mm ball-nose Allen key (ball end) to 45 in.-lbs. (5 Nm).
- Re-install Outer Cover in reverse order of instruction in **STEP #2**.

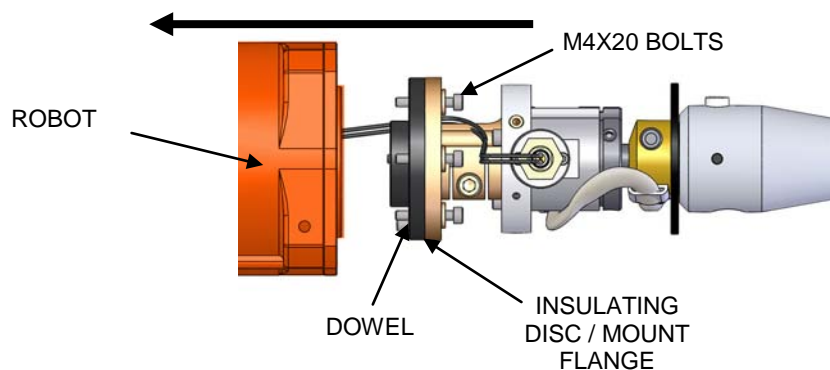

STEP #4 - CONNECTING LSR UNICABLE

- Insert Unicable through mounting face of robot (cutaway of robot shown below).
- Insert Unicable Connector into flange-cable connector. Ensure components are fully seated. Tregaskiss Low Stress Robotic Unicable shown here (See **Section 2.0 INSTALLATION**)
- Secure by tightening M6x20 SHCS, using 5 mm Allen key to 80 in.-lbs. (9 Nm).
- Connect wire connectors (non polarity specific).
- **IMPORTANT:** Leave slack loop around flange for articulation.

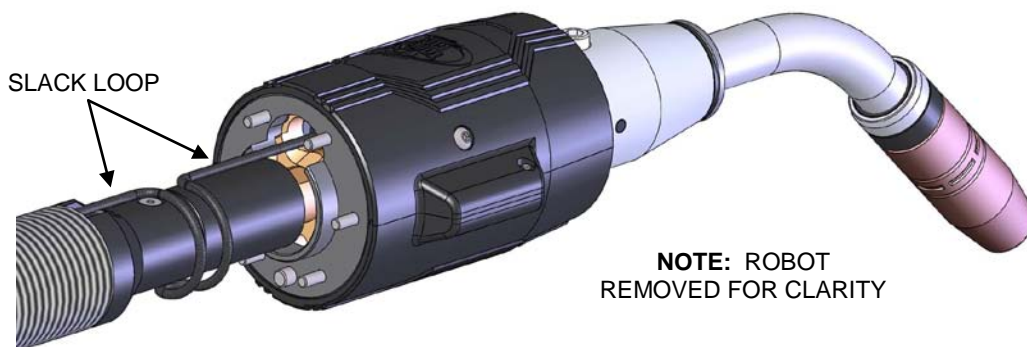

STEP #5 - INSTALLING GOOSENECK

- Insert new gooseneck over the liner and into connector housing until neck is fully seated.
- Once fully seated and secured into place, see **STEP #7** for liner trimming instructions.
- **NOTE:** For best results, install the gooseneck without the consumables so that the liner can pass through easily.

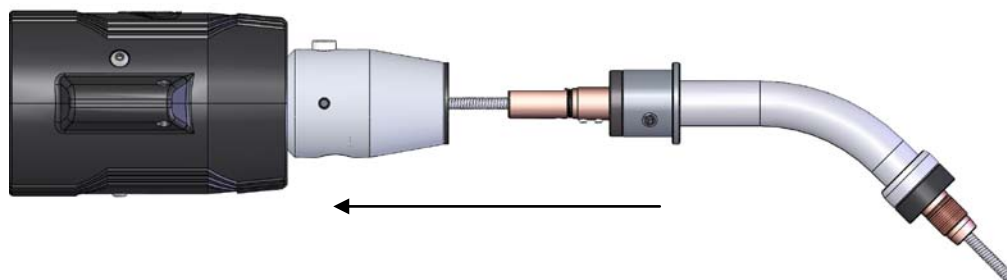

- Tighten Gooseneck bolt clockwise with 5 mm Allen key to torque specifications (60 in.-lbs. or 7Nm). **IMPORTANT:** Do not over-tighten bolt or damage may occur.

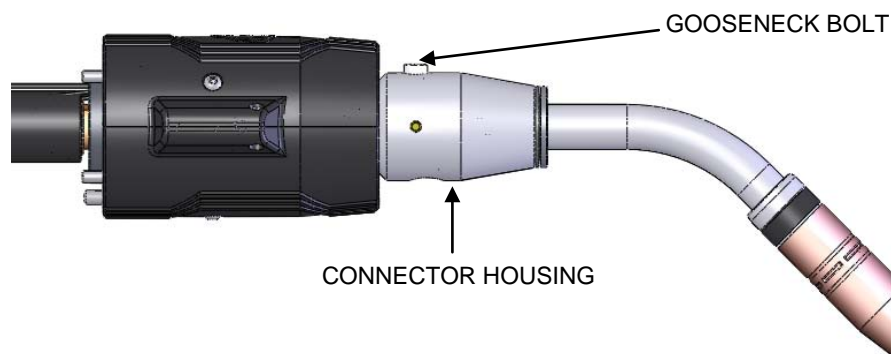

STEP #6 - INSTALLING POWER PIN TO THE LSR UNICABLE

Option #1 of 2: Power Pins

- Install power pin onto the LSR Uncable.
NOTE: Power pins incorporate a taper to seat and lock the pin to the rear handle block. Make sure the power pin is tightened in the block with a wrench to insure the pin is secure and will not come loose.
 - Thread power pin into the adapter of the LSR Uncable.
 - Tighten the power pin into the rear block using a 1" (25 mm) wrench on the rear block and a 5/8" (16 mm) or 3/4" (19 mm) wrench on the power pin.

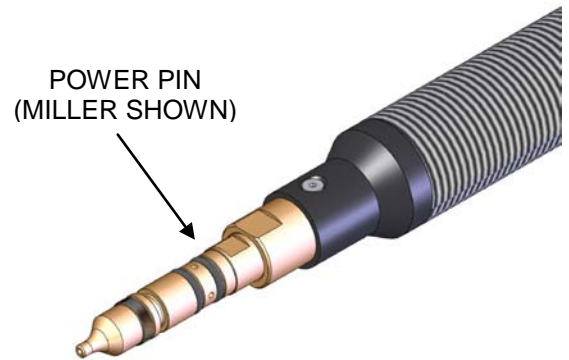

Option #2 of 2: Euro Connection

- The Euro connection comes factory installed. No installation required.



STEP #7 - INSTALLING QUICK LOAD LINER

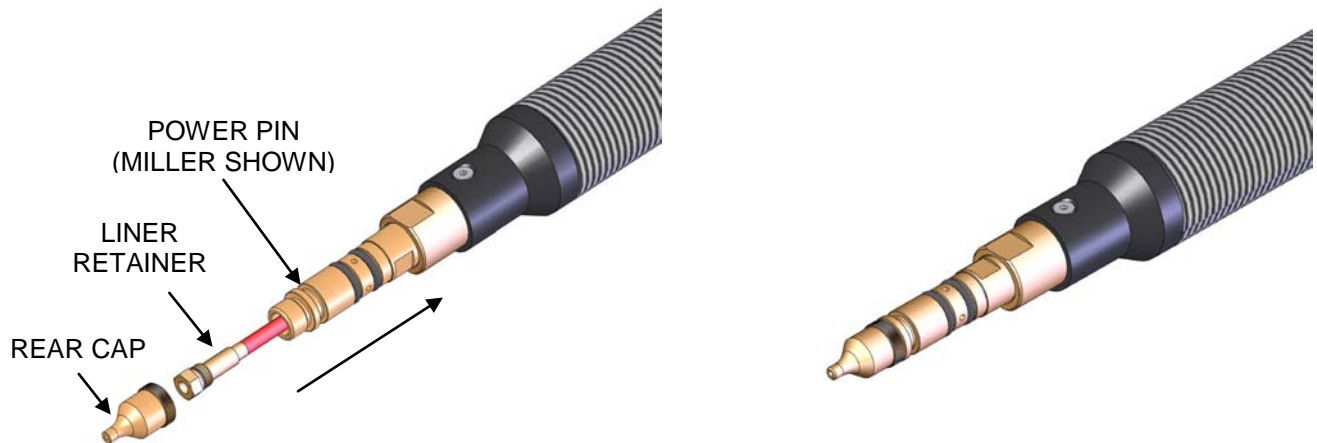

- Remove the rear cap of the power pin.
- Insert brass end of liner into the liner retainer until firmly seated.
- Insert non-brass end of QUICK LOAD™ Liner into back of the gun and push through until it emerges from the front of the gun and the liner retainer makes contact with the power pin.
- Thread the QUICK LOAD Liner retainer (#415-26) into the power pin. Torque to 30 in.-lbs. (3.5 Nm).
- Re-thread the cap of the power pin back on (hand tighten).
- Push liner back into front of gun and hold in place.
- Trim liner to a 5/8" (16 mm) stick out.
- Remove any burrs that may obstruct wire feed.



STEP #8 - INSTALLING CONSUMABLES

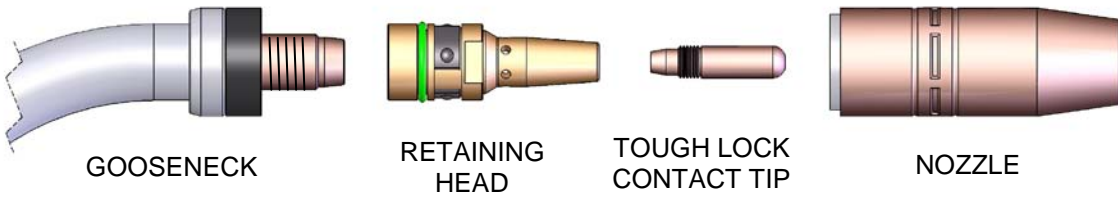

Retaining Head

- Thread the retaining head onto the gooseneck.
- Use a 5/8" wrench and tighten to 80 in.-lbs. (or 9 Nm).

Contact Tip

- Thread the contact tip into the retaining head.
- Torque to 30 in.-lbs. (3.5 Nm).

Nozzle

- Press the slip-on TOUGH GUN Nozzle over the retaining head/contact tip combo until the nozzle is fully seated.
- **IMPORTANT:** Be sure all consumables are tightened properly and fully seated before welding to prevent overheating.

STEP #9 - INSTALLING GUN TO WIRE FEEDER

- Feed the cable through the hole in the body of the robot.
- Install the control cable (for LSR Systems with Clutches ONLY).
 - Connect the jumper control cable to the main control cable of the LSR System.
 - Connect to the wire feeder as per the manufacturer's instructions.
- Install into wire feeder as per the manufacturer's instructions.

3.0 – MAINTENANCE

3.1 REPLACEMENT / ADJUSTMENT OF CLUTCH LIMIT SWITCH

- Feed wires of switch through center holes of switch base and jam nut as shown in exploded view.
- Thread switch base far enough down on the switch body so that the switch will not bottom out when the assembly is fastened to the clutch.
- Position switch assembly (with o-ring) in the clutch housing.
- Insert the two M3 x 0.5 x 6 Hex SHCS into the holes in the switch base and fasten assembly to the clutch.
- Adjust switch by rotating switch itself in the switch base to the appropriate depth. Check normally closed switch using ohmmeter to set desired level of sensitivity.
- Once desired sensitivity is achieved, lock position of switch by torquing jam nut (50 in.-lbs./5.6 Nm) against switch base.

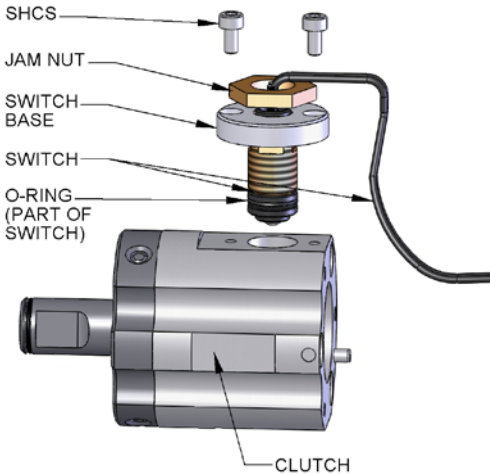

EXPLODED VIEW

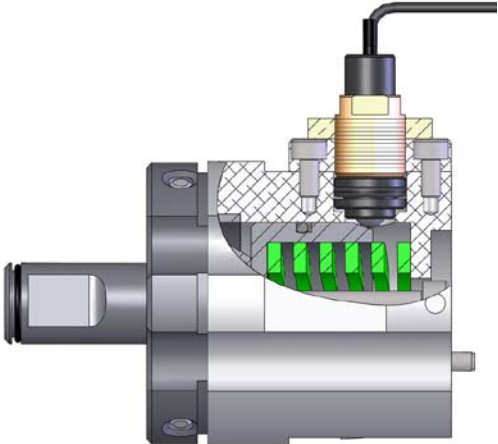

FINISHED ASSEMBLY

3.2 REPLACEMENT OF EURO CONNECTION

- Remove M5 x 6mm countersunk fasteners.
- Slide the hand nut over the Euro power pin body.
- Torque the power pin body to the threaded end of the unicable at 18 ft.-lbs. (24 Nm) using 7/8" & 13/16" wrenches. You may have to pull back on the outer conduit to achieve this.
- Once the power pin body is in place, pull the conduit down over it. Rotate the conduit so that the holes on the power pin line up with the holes on the plastic end of the conduit.

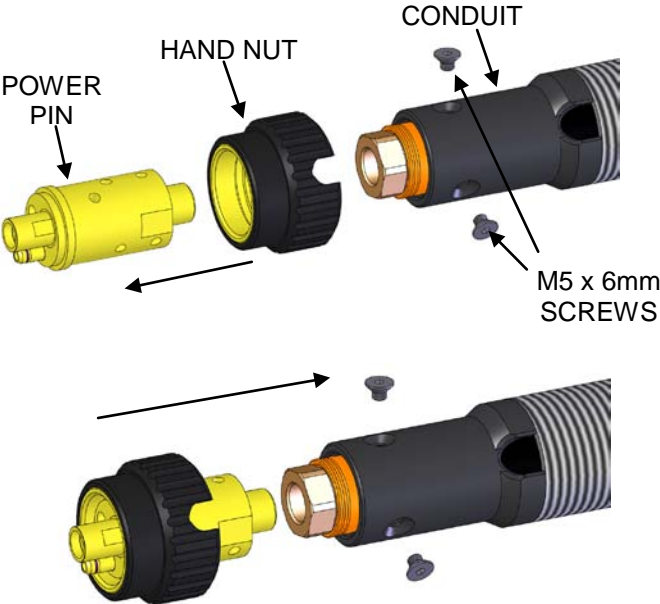

- Insert the two M5 x 6mm countersunk screws and torque to 12 in.-lbs. (1.35 Nm). You may have to rotate the hand nut to access the holes.



3.3 REPLACEMENT OF QUICK LOAD™ LINER

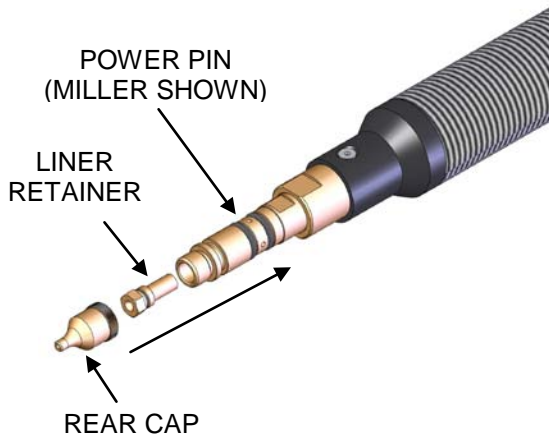

- Remove the rear cap of the power pin.
- Remove the QUICK LOAD Liner retainer (#415-26) from the power pin and thread in new one. Torque to 30 in.-lbs. (3.5 Nm). **NOTE:** One liner retainer can last for multiple liner replacements. Therefore this step is not required for every liner change.
- Re-thread the cap of the power pin back on (hand tighten).
- Next, install QUICK LOAD Liner through front of gun (gooseneck).
- Ensure liner is completely seated in retainer at rear of cable.
- Push liner back into front of gun and hold in place.
- Trim liner to a 5/8" (16 mm) stick out.
- Remove any burrs that may obstruct wire feed.

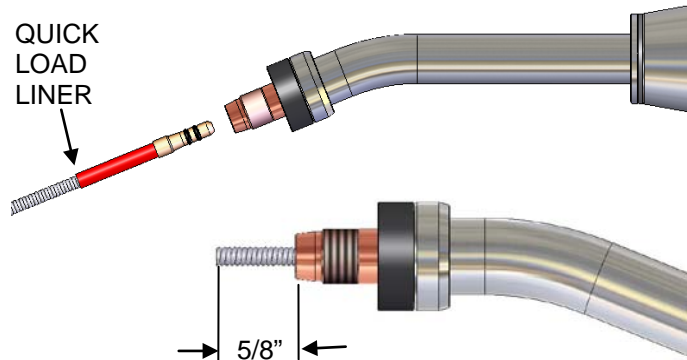

4.0 – TECHNICAL DATA

4.1 GUN CONFIGURATIONS

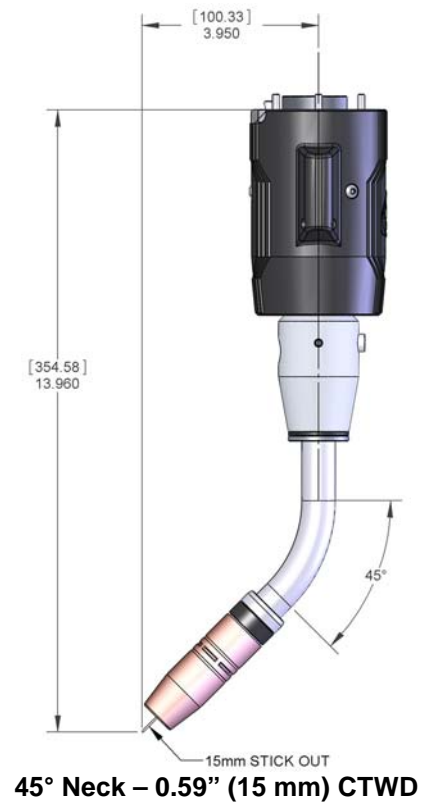
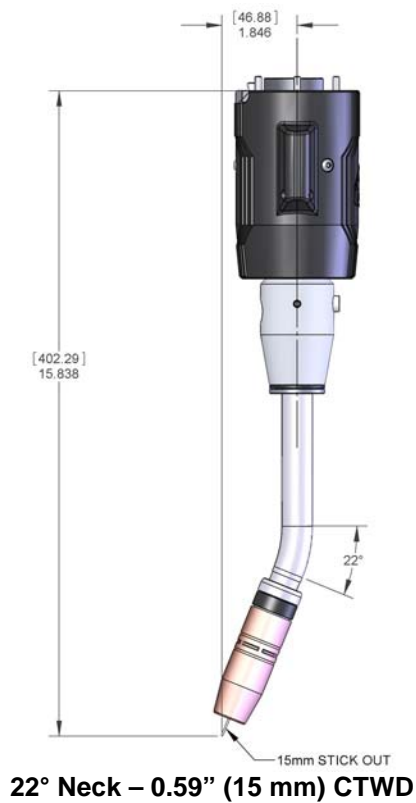

4.2 CENTER OF MASS

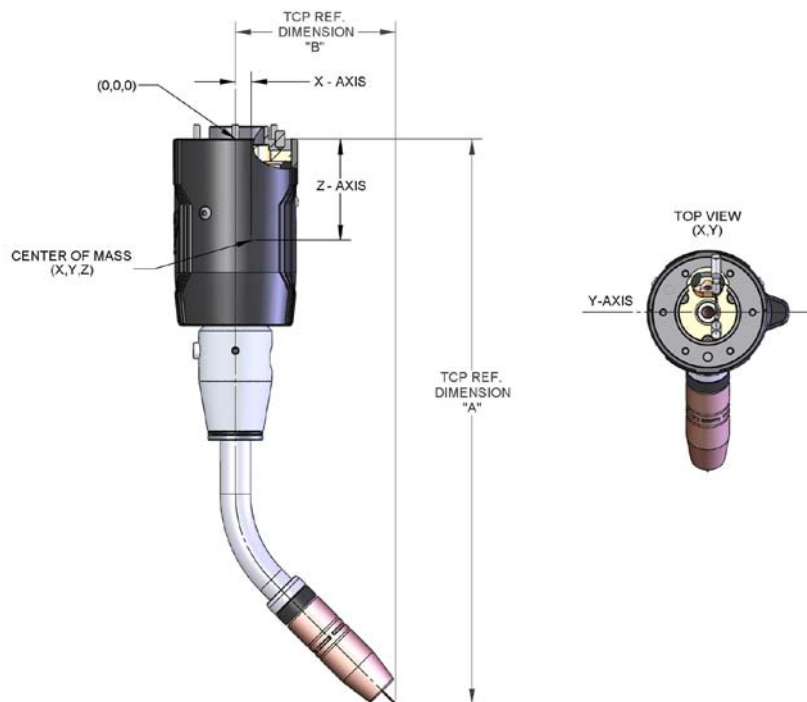

	22° NECK	45° NECK
X	0.14" (3.60 mm)	0.33" (8.38 mm)
Y	0	0
Z	-4.9" (124.46 mm)	-4.65" (-118.11 mm)
WEIGHT	3.94 lbs. (1.79 kg)	3.89 lbs. (1.76 kg)
TCP REF. DIM. "A"***	15.84" (402.34 mm)	13.96" (354.58 mm)
TCP REF. DIM. "B"***	1.85" (46.99 mm)	3.95" (100.33 mm)

**WITH 0.59" (15 mm) WIRE STICKOUT

4.3 AMPERAGE RATINGS*

MODEL	60% DUTY CYCLE - MIXED GASES OR 100% DUTY CYCLE - CO ₂
THRUARM SERIES – AIR-COOLED	500 amp

*Ratings are based on tests that comply with IEC 60974-7 standards.

5.0 – EXPLODED VIEW & PARTS LIST – K5800

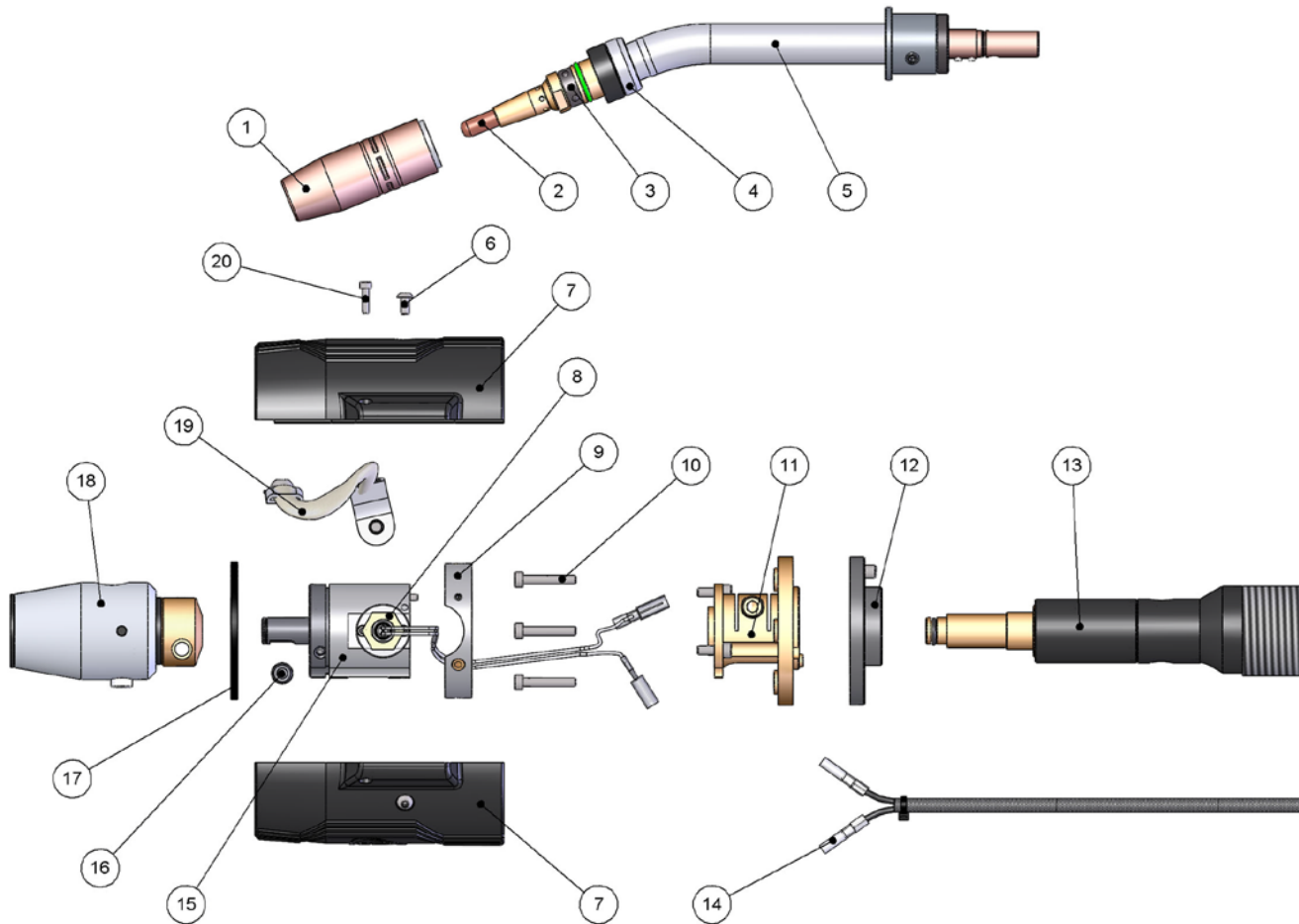

PART #	DESCRIPTION
1	401-X-XX NOZZLE
2	403-XX-35 CONTACT TIP - .035 WIRE
	403-XX-45 CONTACT TIP - .045 WIRE
3	404-XX RETAINING HEAD
4	402-11 GOOSENECK INSULATOR
5	405-22QC GOOSENECK 22 DEG
	405-45QC GOOSENECK 45 DEG
6	M4X.7X8 LG S.B.H.C.S.
7	580-5A OUTER COVER – AC (KIT INCLUDES ITEMS 6, 20)
8	AS-714-9 CLUTCH SWITCH ASSEMBLY
9	AS-114-3 MOUNTING RING ASSEMBLY
10	M4X.7X20 LG S.H.C.S.

PART #	DESCRIPTION
11	580-18 FLANGE CABLE CONN. SET
12	AS-114-6 INSULATING DISC
13	58CK021 LSR UNICABLE FOR KUKA KR5 ARC HW
14	CONTROL CABLE (COMES WITH LSR UNICABLE)
15	AS-714 CLUTCH ASSEMBLY
16	580-3 LOCK PIN AND SCREW
17	580-2-3 RUBBER WASHER
18	580-2 CONNECTOR HOUSING
19	580-4 SHUNT CABLE ASSEMBLY
20	M3X.5X12 LG S.H.C.S.

6.0 – PARTS LISTS FOR K5800A, K5800W, & K5800AW MODELS

6.1 WIRE BRAKE FOR K5800W MODELS

NOTE: Wire brake can only be used if gun was originally ordered with wire brake option. The QUICK LOAD Liner is not offered for Wire Brake gun assemblies.

ITEM	PART #	DESCRIPTION
1	450-17	HOLDER TOOL
2	495-18-35	JUMP LINER FOR ≤ 0.045 "
	495-18-116	JUMP LINER FOR ≥ 0.052 "
3	499-045	PUSHING UNIT FOR UP TO 0.045" WIRE
	499-116	PUSHING UNIT FOR 0.052" TO 1/16" WIRE
4	499-9-15	AIR LINE 15'
5	598	HOLDER FOR ≤ 0.045 "
	598-116	HOLDER FOR ≥ 0.052 "

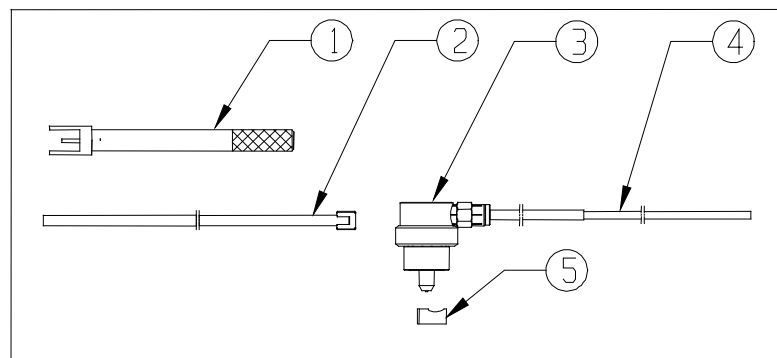

6.2 AIR BLAST FOR K5800A & K5800AW MODELS

NOTE: Run Air Blast Line through the same hole as the Control Cable. See **Technical Guide Addendum M076 Air Blast Installation for ThruArm Series Robotic MIG Guns** on our website at www.tregaskiss.com for details or call Tech Services at 1-877-737-3111 for assistance.

PART #	DESCRIPTION
580-A	AIR BLAST KIT (INCLUDES 15' OF AIR LINE AND AIR FITTING)

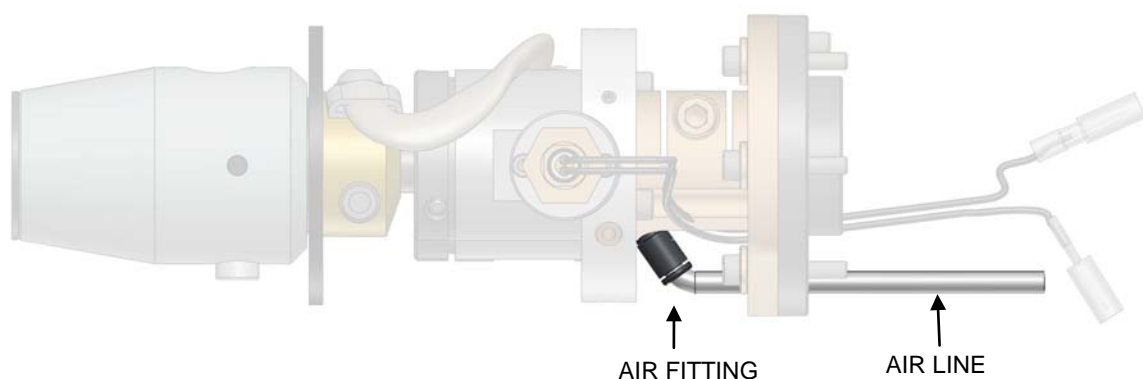

7.0 – ORDERING INFORMATION

To order replacement parts for your TOUGH GUN ThruArm Series Robotic MIG Gun, please contact your authorized Tregaskiss distributor.

For help with configuring a part number for a new TOUGH GUN ThruArm Series Robotic MIG Gun, visit www.tregaskiss.com/thruarm for a complete list of available options to fill in the 10 digit part number below. Tregaskiss Customer Service can also assist you via phone at 1-877-737-3111 (from Canada and USA) or +1-519-737-3000 (international).

STEP 1: Select Your Robot Model					STEP 2: Enter Your Configuration Options (visit www.tregaskiss.com/thruarm for details)					
Robot Model	1 ThruArm Series	2 Robot Brand	3 Robot Model 1	4 Robot Model 2	5 Gun Mount & Option	6 Nozzle	7 Neck	8 Contact Tip	9 Wire Size	10 Power Pin
KR5 arc HW	T	K	2	1						
	T	K	2	1	1	G	C	1	D	D
	ThruArm Series	KUKA	KR5 arc HW		Clutch System	Bottleneck Standard Duty, Copper, 1/2" Bore, 1/8" stick-out (#401-48-50C)	45 degree Air-Cooled Quick-Change Neck (#405-45QC)	TOUGH LOCK Heavy Duty Contact Tip (#403-20 series)	Wire Size 1.0mm (#403-20-1.0 contact tip)	OTC Power Pin (#214-1)



For Technical Support:

Canada & U.S.A. Phone: 1-877-737-3111

International Phone: +1-519-737-3000

Email: techservices@tregaskiss.com

www.tregaskiss.com

Distributed by:

05/11

M078 REV B