

TECHNICAL GUIDE
**TOUGH GUN™ REAMER
TT Series**

For Serial #TT-11300 and higher

- SAFETY & WARRANTY
- INSTALLATION
- MAINTENANCE GUIDE
- TECHNICAL DATA
- OPTIONS
- EXPLODED VIEW & PARTS LIST
- TROUBLESHOOTING
- ORDERING INFORMATION

Certified ISO 9001:2008
Please read instructions prior to use.
Save this manual for future reference.

TABLE OF CONTENTS

WARRANTY.....	2
THANK YOU.....	3
GENERAL SAFETY.....	3
1.0 – INSTALLATION / SETUP.....	4
1.1 INSTALLING TOUGH GUN REAMER.....	4
1.2 AIR MOTOR LUBRICATION.....	5
1.3 WIRING INTERFACE CONNECTIONS.....	5
1.4 ACCESS TO ELECTRICAL AND PNEUMATIC CONTROLS.....	5
1.5 CIRCUIT BOARD LOGIC INVERSE.....	5
1.6 L.E.D. INDICATORS.....	6
1.7 NOZZLE HEIGHTS FOR CUTTER BLADE INSERTION.....	6
1.8 PROGRAMMING EVENTS SEQUENCE.....	7
1.9 V-BLOCK SETUP.....	7
1.10 MANUAL REAMER SETUP.....	7
1.11 FLOW CONTROL VALVE(S).....	7
2.0 – MAINTENANCE.....	8
2.1 AIR MOTOR REPLACEMENT.....	8
2.2 REPLACEMENT OF PRINTED CIRCUIT BOARD.....	8
2.3 CUTTER BLADE REPLACEMENT.....	9
2.4 BELT REPLACEMENT.....	9
2.5 SOLENOID VALVE REPLACEMENT.....	9
2.6 SCHEDULED MAINTENANCE PROGRAM.....	10
3.0 – TECHNICAL DATA.....	10
3.1 PNEUMATIC DIAGRAM.....	10
3.2 ELECTRICAL SCHEMATIC.....	11
3.3 CUTTER BLADE AND V-BLOCK CHART.....	12
4.0 – EXPLODED VIEW AND PARTS LIST.....	13
5.0 – TROUBLESHOOTING.....	14
6.0 – SPRAYER (OPTION).....	14
6.1 ANTI-SPATTER SPRAYER.....	14
6.2 SPRAYER PROGRAMMING EVENTS SEQUENCE.....	15
6.3 SPRAYER MAINTENANCE.....	15
6.4 SPRAYER TROUBLESHOOTING.....	15
6.5 SPRAYER PARTS LIST – SR-500.....	16
7.0 – ADDITIONAL OPTIONS.....	16
7.1 REAMER STAND WITH OPTIONAL SMC FRL (FILTER REGULATOR LUBRICATOR).....	16
7.2 FLOW CONTROL.....	17
7.3 WIRE CUTTER.....	17
8.0 – MULTI-FEED READY REAMER.....	18
9.0 – ORDERING INFORMATION.....	19

WARRANTY

Product is warranted to be free from defects in material and workmanship for the period specified below after the sale by an authorized Buyer. Should there be a defect, please refer to our Return Merchandise Policy.

PRODUCT	WARRANTY PERIOD
TOUGH GUN™ MIG Guns and Components	180 days
TGX™ Chassis and TGX Ready To Weld MIG Guns	90 days
TOUGH GUN Reamer	1 year
TOUGH GARD™ Spatter Cleaner	1 year
TOUGH GUN Robotic Peripherals (Clutch, Sprayer, Wire Cutter, Clutch Disc, Mounting Arms)	1 year
Low-Stress Robotic Unicables (LSR Unicables)	2 years

Tregaskiss reserves the right to repair, replace or refund the purchase price of non-conforming product. Product found not defective will be returned to the Buyer after notification by Customer Service.

Tregaskiss makes no other warranty of any kind, expressed or implied, including, but not limited to the warranties of merchantability or fitness for any purpose. Tregaskiss shall not be liable under any circumstances to Buyer, or to any person who shall purchase from Buyer, for damages of any kind, including, but not limited to any direct, indirect, incidental or consequential damages or loss of production or loss of profits resulting from any cause whatsoever, including, but not limited to any delay, act, error or omission of Tregaskiss.

Genuine Tregaskiss parts must be used for safety and performance reasons or the warranty becomes invalid. Warranty shall not apply if accident, abuse, or misuse damages a product, or if a product is modified in any way except by authorized Tregaskiss personnel.

THANK YOU...

...for selecting a TOUGH GUN™ Reamer. Manufacturing operations demand extremely dependable robotic equipment. With this in mind, the TOUGH GUN Reamer was designed and engineered to be a reliable tool to support high production within a robotic cell. As the name implies, the TOUGH GUN Reamer is made from durable materials and components engineered to perform in a rugged robotic welding environment.

The instructions and illustrations in this Technical Guide make it easy for you to maintain your TOUGH GUN Reamer. **Please read, understand, and follow all safety procedures.** Keep this Technical Guide booklet as a handy reference when ordering complete guns, parts and special options.

For technical support and special applications, please call the Tregaskiss Technical Service Department at 1-877-737-3111 or fax 1-877-737-2111. Our trained technicians are available between 8:30 AM and 4:30 PM EST, and will answer your application or repair questions.

Tregaskiss also manufactures complete robotic MIG gun systems designed and engineered to perform as a team in the high-volume robotic production environment. Components include TOUGH GUN Robotic Air-Cooled and Water-Cooled MIG Guns, TOUGH GUN Clutch and Mounting Arms. Contact your Tregaskiss representative or Tregaskiss for further information.

GENERAL SAFETY

Before installation or operation of the TOUGH GUN Reamer, please read and understand all safety precautions listed below. Failure to follow these instructions may result in personal injury or damage to the equipment.

1. Do not remove or deface warning and instruction labels from the unit.
2. Ensure that all equipment in the area is disabled and locked out before setting up, adjusting or conducting any work.
3. Ensure that electrical and pneumatic power to unit is off before performing maintenance or troubleshooting.
4. Ensure reset button is pressed to reset circuit board logic before doing any maintenance or troubleshooting with electrical power and/or pneumatic power on.
5. Check that electrical and pneumatic connections comply with the codes applicable to your country and state.
6. Keep hands away from unit while in operation.
7. For additional safety information, please refer to the following publications:

ANSI STANDARD Z49.1, SAFETY IN WELDING AND CUTTING,
American Welding Society, 550 LeJeune Rd. P.O. Box 351040, Miami, FL 33126

ANSI STANDARD, SAFETY FOR ROBOTS AND ROBOT SYSTEMS,
American National Standards Institute, 1430 Broadway, New York, NY 10018

NFPA STANDARD 70-1978, NATIONAL ELECTRIC CODE,
National Fire Protection Association, 1470 Atlantic Avenue, Boston, MA 02210

CALIFORNIA PROPOSITION 65 WARNING

This product, when used for welding or cutting, produces fumes or gases which contain chemicals known to the State of California to cause birth defects and, in some cases, cancer.

This product contains chemicals, including lead, known to the State of California to cause cancer, and birth defects or other reproductive harm. *Wash hands after use.*

(California Health & Safety Code Section 25249.5 at seq.)



1.0 – INSTALLATION / SETUP

1.1 INSTALLING TOUGH GUN™ REAMER

WARNING: ENSURE POWER SUPPLY IS OFF AND DISCONNECTED BEFORE PROCEEDING.

Mounting Hole Locations and Footprint

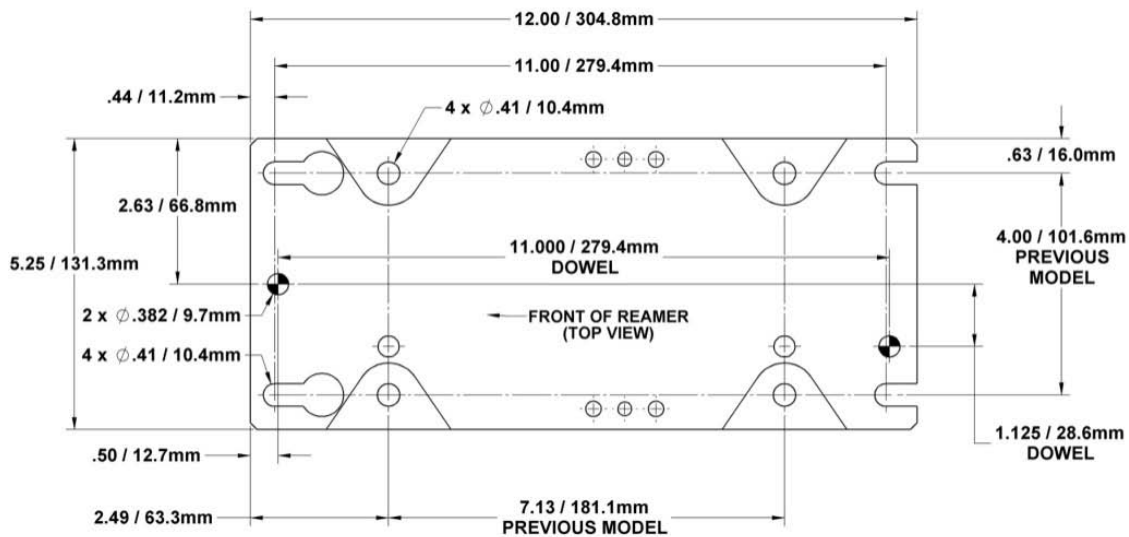

Dimensions

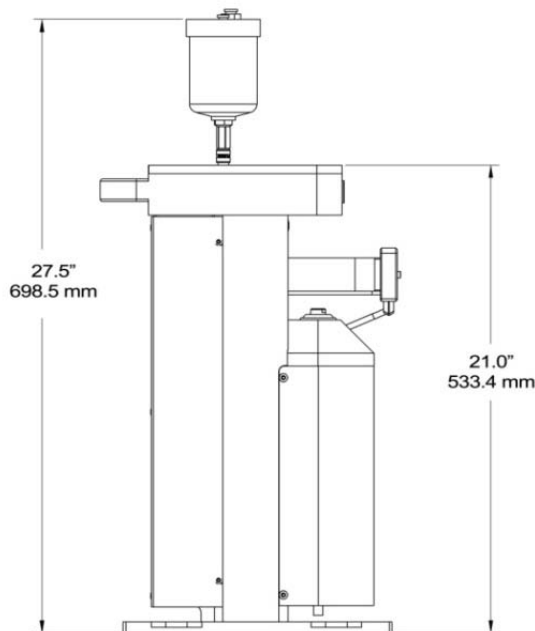

MOUNTING REAMER

- The TOUGH GUN Reamer should be installed within the weld cell at a convenient location. Be sure to consider movable fixtures and the working envelope of the robot.
- Affix Reamer base to sturdy platform using four (4) bolts (provided).

CONNECTING AIR SUPPLY

WARNING: PUSH RESET BUTTON BEFORE CONNECTING AIR LINE.

- Use only filtered, lubricated air.
- REQUIREMENTS - **IMPORTANT:** 80 to 100 psi at 16 CFM (5.0 - 7.0 BAR at 450 LPM) at the Reamer during operation.
- Use an air supply line with an inside diameter of 3/8". Connect to 1/4" female NPT inlet located on the side of the reamer.

1.2 AIR MOTOR LUBRICATION

An air line lubricator (not supplied) must be mounted in the air line of the TOUGH GUN Reamer. The Lubricator should be set to feed one drop of oil for every 50-75 CFM of air going through the motor (approximately every 3-5 cycles). The lubricant can be air motor oil or light grade hydraulic oil with a viscosity rating of 150 VC 15-20 (SAE 5W).

1.3 WIRING INTERFACE CONNECTIONS

WARNING: THE FOLLOWING CONNECTIONS SHOULD ONLY BE PERFORMED BY QUALIFIED TECHNICIANS. DAMAGE TO EQUIPMENT WILL OCCUR IF CONNECTIONS ARE INCORRECT.

To interface the TOUGH GUN Reamer with the controller, 4 electrical connections are required (5 if using Sprayer):

- ORANGE LEAD - CYCLE START INPUT (0.25 AMP)
- WHITE LEAD - 0 VDC SUPPLY 0.5 AMP
- RED LEAD - 24 VDC SUPPLY 0.5 AMP
- GREEN LEAD - JAWS UNCLAMPED OUTPUT (LOAD CAPACITY = 0.25 AMP)
- BLACK LEAD - OPTION / SPRAYER (INPUT)

NOTE: The pre-wired interface receptacle uses the above color codes.

OPERATION NOTES:

NOTE: The circuit board of the TOUGH GUN Reamer is capable of both sourcing or sinking inputs and outputs:

- Connection 2 - RED LEAD. 24 VDC supply that operates the board.
- Connection 3 - GREEN LEAD. *Cycle Complete Signal* has one of two settings: 1) Sourcing, OR 2) Sinking.
- Connection 4 - ORANGE LEAD. *Cycle Start Signal* (Start Signal should be a pulse with a maximum of 0.5 seconds in duration) has one of two settings: 1) Board set to "Sourcing" (Robot sends "high" signal or +24 VDC), or 2) Board set to "Sinking" (Robot sends "low" signal or 0 VDC). See **Section 1.5 LOGIC INVERSE** for more information.

1.4 ACCESS TO ELECTRICAL AND PNEUMATIC CONTROLS

WARNING: ENSURE POWER SUPPLY IS OFF AND DISCONNECTED BEFORE PROCEEDING.

- To access the electronic circuit board for installation or service of the TOUGH GUN Reamer, simply loosen the 2 Metric screws using a 3 mm Allen wrench to open the hinged access door.
- The shroud can be completely removed if accessibility is an issue. Simply loosen the 3 Metric screws using a 3 mm Allen wrench and remove shroud.

M5 x 0.8 x 16 mm
SBHCS SCREWS

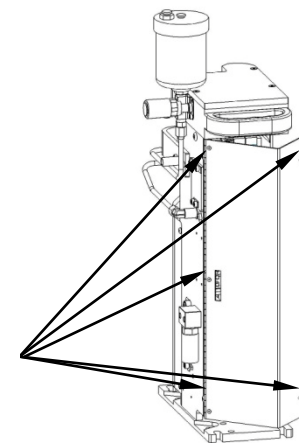

1.5 CIRCUIT BOARD LOGIC INVERSE

CAUTION! BEFORE START-UP, ENSURE THAT ALL CONNECTIONS ARE CORRECT OR DAMAGE TO THE TOUGH GUN REAMER MAY OCCUR.

NOTE: The TOUGH GUN Reamer is factory set for sourcing inputs and outputs.

DEFINITIONS: SINKING = signal from robot is LOW SOURCING = signal from robot is HIGH

- See **Section 3.2 ELECTRICAL SCHEMATIC**.
- The control logic requirement for some installations may require an inverse of the logic provided. The inverse logic is 0 VDC low (sinking) input or outputs.
- To switch from sourcing to sinking, the switches located inside the motor shroud must be accessed. See **Section 1.4 ACCESS TO ELECTRICAL AND PNEUMATIC CONTROLS** above for directions.
- Although the circuit board is protected, Tregaskiss suggests disconnecting the power before moving the switches.
- The switches are located on the top left-hand corner of the circuit board.
- The Output signal (*unclamped signal*) can be altered to either sourcing or sinking by moving the switch (SW3) to the position indicated in the diagram.
- The Input signal (*start signal*) can be altered to either sourcing or sinking by moving the switch (SW2) to the position indicated in the diagram.
- The Option signal (*sprayer*) can be altered to either sourcing or sinking by moving the switch (SW1) to the position indicated in the diagram.

1.6 LED INDICATORS

The LED indicators mounted on the front of the TOUGH GUN Reamer supply visual information regarding cycle status. This information may be used for both installation and maintenance to verify proper operation. When the TOUGH GUN Reamer is idle, LED status should be:

- “Reamer Home” - ON
- “Clamp / Motor Valve Short” - OFF
- “Reamer Ahead” - OFF
- “Sprayer Valve Short” - OFF
- “Unclamped” - ON
- “Feed Valve Short” - OFF (Feed Valve = Spindle Valve)

“**Reamer Home**” - indicates that the lift cylinder has retracted, the cutter is at the bottom of its stroke and the limit pin is activating the lower limit switch.

“**Clamp / Motor Valve Short**” - indicates short with clamp or motor valve.

“**Reamer Ahead**” - indicates that the Reamer has reached full upper stroke and the limit pin is activating the upper limit switch.

“**Sprayer Valve Short**” - indicates short with sprayer / option valve.

“**Unclamped**” - indicates that the clamp cylinder is fully retracted, releasing the clamp mechanism and supplying an output signal that the cycle is complete (via the limit switch mounted next to the clamp cylinder).

“**Feed Valve Short**” - indicates short with feed valve (also referred to as “spindle valve”).

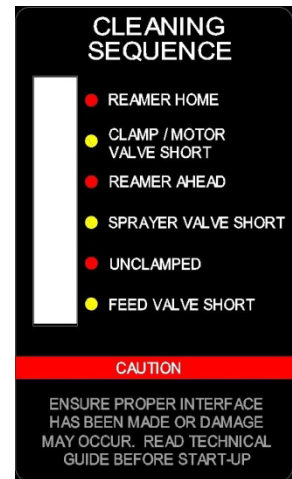

1.7 NOZZLE HEIGHTS FOR CUTTER BLADE INSERTION

CUTTER BLADE	NOZZLE	RETAINING HEAD					
		404-3		404-20 / 404-26 / 404-30 / 404-32		454-1	
RC-06	3/8" (9.53 mm)	.023" BELOW	.564 mm BELOW	.025" BELOW	.635 mm BELOW	.266"	6.76 mm
RC-12	3/4" (19.05 mm)	.110" BELOW	2.79 mm BELOW	.110" BELOW	2.79 mm BELOW	.466"	11.84 mm
RCT-01	5/8" (15.88 mm)	.030"	.762 mm	.060"	1.52 mm	.716"	18.19 mm
RCT-04	1/2" (12.7 mm)	.219" BELOW	5.56 mm BELOW	.065"	1.65 mm	.065"	1.65 mm

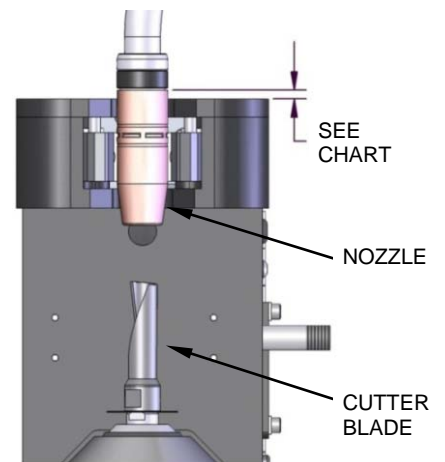

1.8 PROGRAMMING EVENTS SEQUENCE

1. Verify the TOUGH GUN Reamer input showing “Clamps Open”.
2. Position the robot to place the MIG gun at a right angle to the unit and to insert the gun to the proper depth, centered and pressed against the v-block (See **Section 1.7 NOZZLE INSERTION HEIGHTS**).
3. Cycle Start - Supply output signal from the robot controller. Pulse output for 0.5 seconds.
4. TOUGH GUN Reamer performs cleaning cycle.
5. Wait and verify input from TOUGH GUN Reamer for cycle (Clamps Closed).
6. Wait and verify input from TOUGH GUN Reamer for *Cycle Complete* (Clamps Open).
7. The robot can now be safely removed from the TOUGH GUN Reamer clamps to the next position.
8. If using anti-spatter sprayer - See **Section 6.0 SPRAYER**.
9. After reaming, center the nozzle above the spray head (See **Section 6.2 SPRAYER PROGRAMMING EVENTS SEQUENCE** for details).
10. Supply output signal from robot controller to the sprayer for about 0.5 seconds (increase or decrease spray time as required).
11. Move robot to next position.

1.9 V-BLOCK SETUP

WARNING: ENSURE POWER SUPPLY IS OFF AND AIR IS DISCONNECTED BEFORE PROCEEDING.

- Remove four cover screws.
- Lift clamp cover off.
- Lift and rotate v-block so desired size faces jaws.
- **NOTE:** Numbers are stamped into the v-blocks. The number refers to the outside diameter of the nozzle (i.e. 0.938 = 0.938 O.D.)

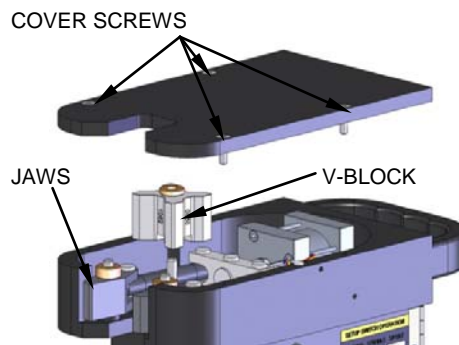

V-BLOCK PART #	NOZZLE OUTSIDE DIAMETER FOR EACH SIDE OF V-BLOCK			
TR-2150 (4 SIDES)	0.850"	0.938"	1.062"	1.106"
TR-2161 (4 SIDES)	0.830"	0.978"	25 mm	1.125"
TR-2162 (4 SIDES)	0.780"	0.813"	0.875"	1.000"

1.10 MANUAL REAMER SETUP

NOTE:

- The manual override switches allow confirmation that the lift cylinder and jaw clamping air circuit is operational.
- To manually operate the TOUGH GUN Reamer, locate the switches on the air supply side of the Reamer as shown.

NOTE: The RESET button should be pressed prior to manual setup to reset all circuitry.

1.11 FLOW CONTROL VALVE(S)

OPERATING NOTES: The flow control valve(s) provide a smooth, constant feed of the cutting tool. The feed rate is dependent on the amount of spatter accumulated. If a smaller amount of spatter accumulates, the feed can be set faster. A feed rate that is set too fast may stall the motor or damage the cutter blade.

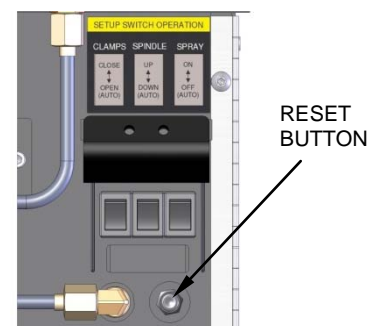

ADJUSTING THE FLOW CONTROL VALVE(S)

- There is a flow control valve for adjustment of the up speed of the feed head. The down (retract) speed is fixed. The feed rate may require adjusting for different applications.
- The valve controls the rate at which air is released on the exhaust side of the cylinder.
- To increase feed rate on the nozzle, the valve would have to be opened, which allows air to flow out of the cylinder thereby increasing speed.
- To decrease feed rate into the nozzle, the valve would have to be closed, which slows air flow out of the cylinder causing feed to slow down.

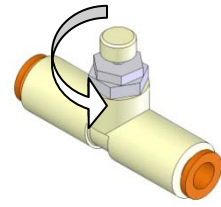

2.0 – MAINTENANCE

2.1 AIR MOTOR REPLACEMENT

- Open motor shroud or remove completely by removing 2 screws using a 3 mm Allen wrench.
- Remove tension lock screw.
- Push motor in to release belt tension.
- Disengage belt.
- Release air lines from quick disconnect air fittings at front of motor.
- Pull out motor. **BE CAREFUL NOT TO LOSE THE MOTOR SPRING.**
- Reverse order for reassembly.

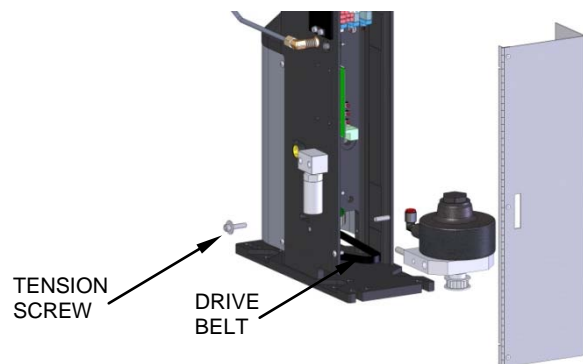

2.2 REPLACEMENT OF PRINTED CIRCUIT BOARD

- Open rear shroud.
- Remove connectors from board being careful not to damage wiring.
- Remove the fasteners which secure board to standoffs.
- **IMPORTANT:** Check to ensure all 4 standoffs are still attached to the frame.
- Board can now be carefully removed from the unit and a new one installed.
- Once located in the proper position, secure board by tightening fasteners.

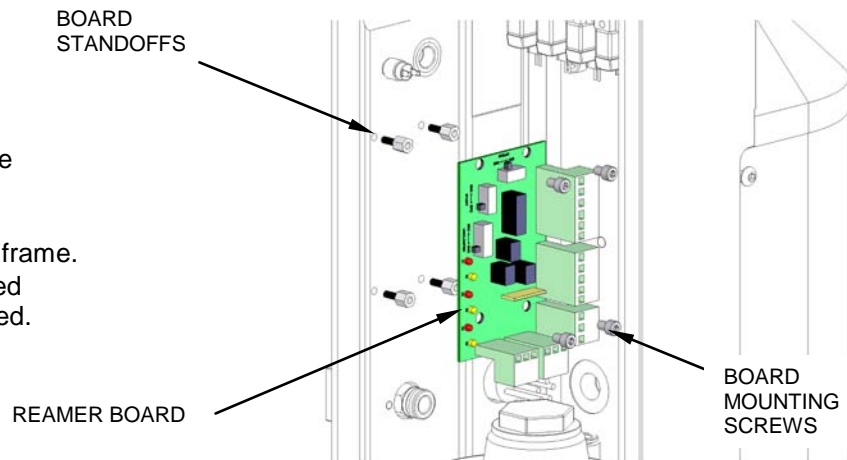

2.3 CUTTER BLADE REPLACEMENT

- Remove cutter blade using a 5/8" wrench and the supplied 9/16" wrench.
- The cutter blade is removed by turning counterclockwise when viewed from above.
- Considerable force may be required to loosen the cutter since it tightens naturally as the Reamer operates.

INSTALLING CUTTER BLADE

The cutter blade is installed by threading it clockwise into the top of the extensions shaft.

NOTE: The application of anti-seize compound to the threads of the TOUGH GUN Reamer cutter will assist in easy removal in the future.

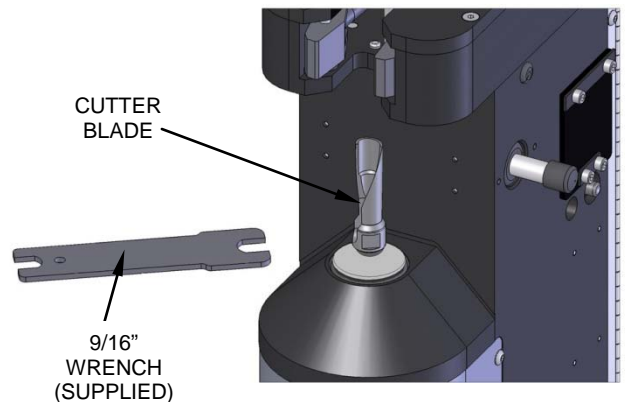

2.4 BELT REPLACEMENT

- Open rear cover.
- Loosen tension lock screw.
- Push motor in to release belt tension.
- Remove belt.
- Reverse order for reassembly.

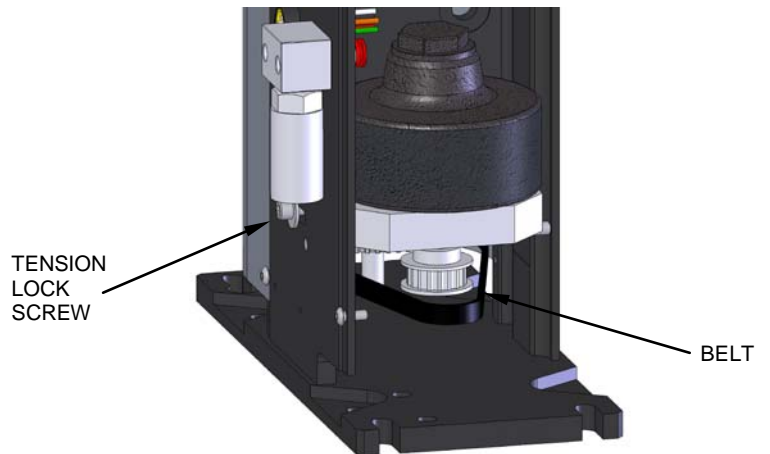

2.5 SOLENOID VALVE REPLACEMENT

- Shut off power to TOUGH GUN Reamer.
- Shut off air supply to TOUGH GUN Reamer.
- Open motor shroud.
- Unplug wires directly from bottom of solenoid valve.
- Loosen and remove (2) solenoid valve screws.
- Remove solenoid valve and gasket.
NOTE: New gasket (included with new valve) must be installed when replacing valve.
- Reinstall new gasket and valve and tighten screws to 6 in.-lbs.
- Reconnect wires to bottom of solenoid valve.
- Close the motor shroud.

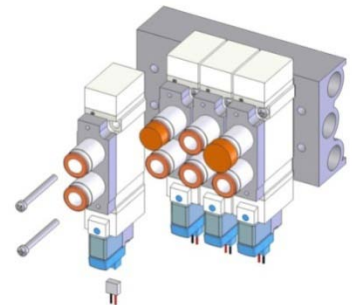

2.6 SCHEDULED MAINTENANCE PROGRAM

The TOUGH GUN Reamer will require a periodic maintenance program to ensure a reliable service life. The following schedule is recommended.

DAILY

- Ensure spindle cover area is clear of spatter.
- Visually check oil level in lubricator reservoir.
- The life of the air motor is dependent on a consistent supply of oil.
- Visually check air lines and interface cable for leaks and fraying.
- Clean clamp jaw surfaces to ensure proper nozzle gripping.

WEEKLY

- Visually check the TOUGH GUN Reamer cutter blade. The service life of the cutter blade is dependent on the type of application.
- In lighter duties, the blade may last indefinitely. However, it should be inspected for dullness, clogging and possible breakage.
- Ensure belt tension lock screw is securely tightened.

YEARLY

- Replace drive belt (See **Section 2.4 BELT REPLACEMENT**).

3.0 – TECHNICAL DATA

3.1 PNEUMATIC DIAGRAM

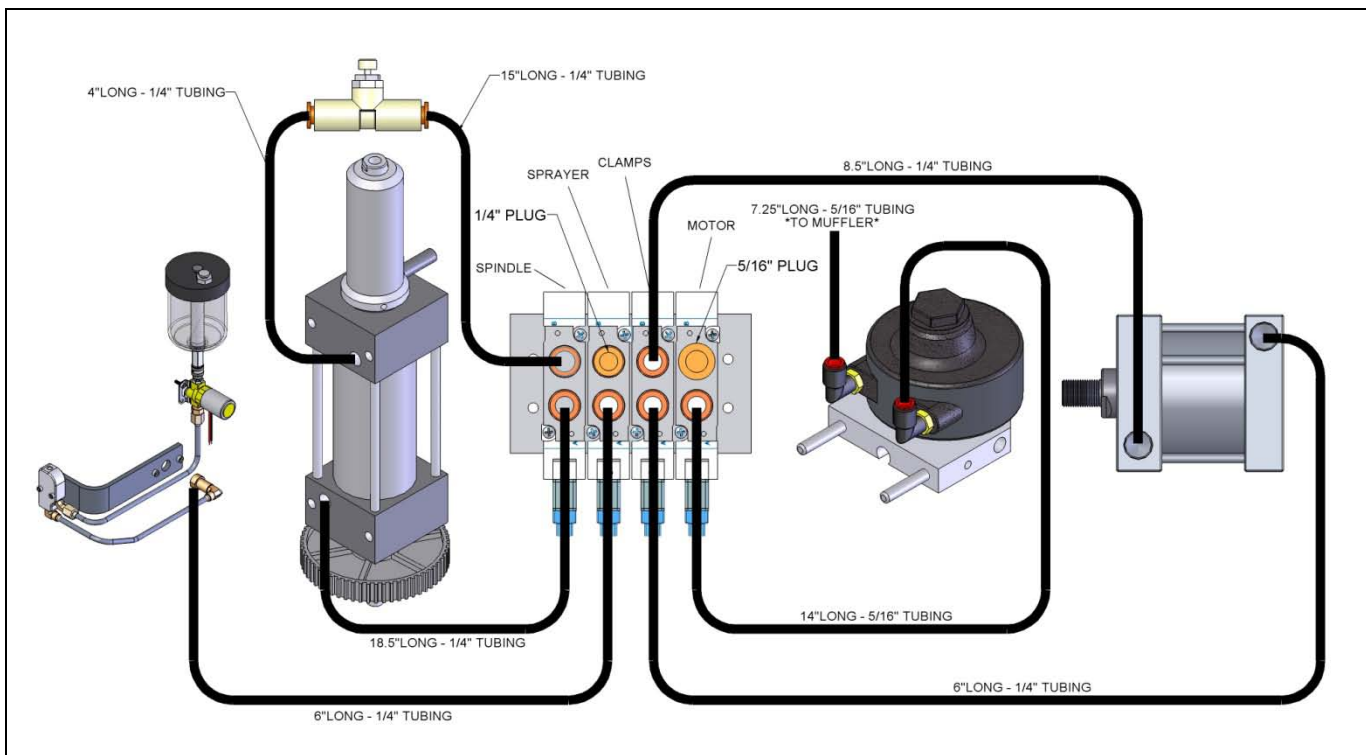

3.2 ELECTRICAL SCHEMATIC

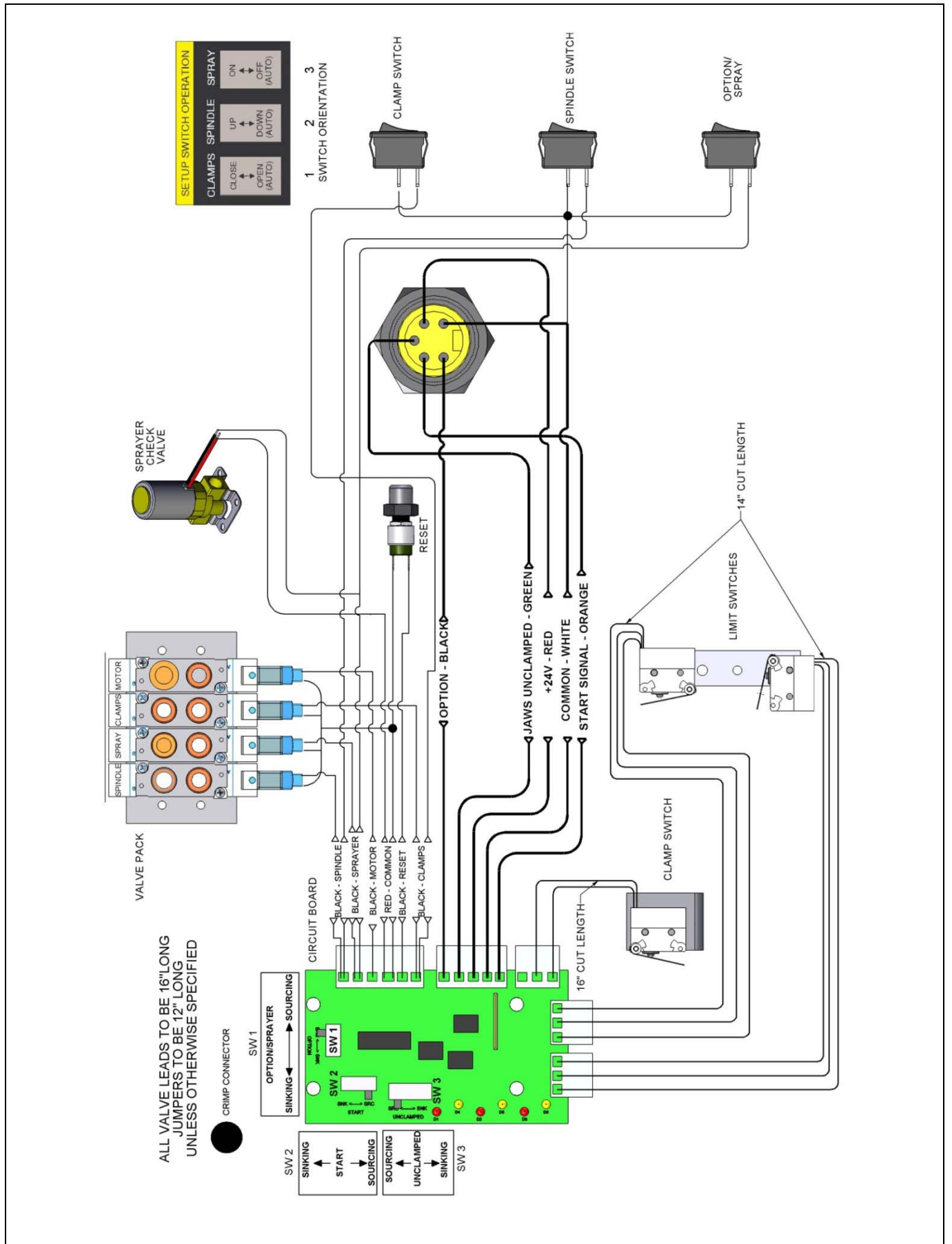

3.3 CUTTER BLADE AND V-BLOCK CHART

NOZZLE PART #	NOZZLE OUTSIDE DIAMETER	REAMER MODEL	V-BLOCK PART #	CUTTER BLADE PART #
401-4-38	0.938"	TT-0938-06	TR-2150	RC-06
401-45-38	0.938"	TT-0938-06	TR-2150	RC-06
401-45-38	0.938"	TT-0938-06	TR-2150	RC-06
401-46-38	0.938"	TT-0938-06	TR-2150	RC-06
451-4-38	0.938"	TT-0938-06	TR-2150	RC-06
401-4-50	0.938"	TT-0938-04	TR-2150	RCT-04
401-6-50	1.060"	TT-1060-04	TR-2150	RCT-04
401-42-50	0.938"	TT-0938-04	TR-2150	RCT-04
401-44-50	0.938"	TT-0938-04	TR-2150	RCT-04
401-45-50	0.938"	TT-0938-04	TR-2150	RCT-04
401-46-50	0.938"	TT-0938-04	TR-2150	RCT-04
401-47-50	0.938"	TT-0938-04	TR-2150	RCT-04
401-48-50	0.938"	TT-0938-04	TR-2150	RCT-04
451-6-50	0.938"	TT-0938-04	TR-2150	RCT-04
401-4-62	0.938"	TT-0938-01	TR-2150	RCT-01
401-5-62	1.060"	TT-1060-01	TR-2150	RCT-01
401-6-62	1.060"	TT-1060-01	TR-2150	RCT-01
401-7-62	1.106"	TT-1106-01	TR-2150	RCT-01
401-8-62	0.938"	TT-0938-01	TR-2150	RCT-01
401-9-62	0.938"	TT-0938-01	TR-2150	RCT-01
401-45-62	0.938"	TT-0938-01	TR-2150	RCT-01
401-46-62	0.938"	TT-0938-01	TR-2150	RCT-01
401-48-62	1.060"	TT-1060-01	TR-2150	RCT-01
401-72-62	1.060"	TT-1060-01	TR-2150	RCT-01
401-81-62	1.060"	TT-1060-01	TR-2150	RCT-01
401-87-62	1.060"	TT-1060-01	TR-2150	RCT-01
451-1-62	1.060"	TT-1060-01	TR-2150	RCT-01
451-5-62	0.938"	TT-0938-01	TR-2150	RCT-01
451-6-62	0.938"	TT-0938-01	TR-2150	RCT-01
451-8-62	0.938"	TT-0938-01	TR-2150	RCT-01
451-61-62	1.060"	TT-1060-01	TR-2150	RCT-01
451-81-62	1.060"	TT-1060-01	TR-2150	RCT-01
451-87-62	1.060"	TT-1060-01	TR-2150	RCT-01
650-5-62	1.060"	TT-1060-01	TR-2150	RCT-01
650-6-62	1.060"	TT-1060-01	TR-2150	RCT-01
651-5-62	1.060"	TT-1060-01	TR-2150	RCT-01
651-6-62	1.060"	TT-1060-01	TR-2150	RCT-01
401-4-75	0.938"	TT-0938-12	TR-2150	RC-12
401-5-75	1.060"	TT-1060-12	TR-2150	RC-12
401-6-75	1.060"	TT-1060-12	TR-2150	RC-12
401-7-75	1.106"	TT-1106-12	TR-2150	RC-12
451-1-75	1.060"	TT-1060-12	TR-2150	RC-12
451-5-75	0.938"	TT-0938-12	TR-2150	RC-12
451-6-75	0.938"	TT-0938-12	TR-2150	RC-12
650-5-75	1.060"	TT-1060-12	TR-2150	RC-12
650-6-75	1.060"	TT-1060-12	TR-2150	RC-12
651-5-75	1.060"	TT-1060-12	TR-2150	RC-12
651-6-75	1.060"	TT-1060-12	TR-2150	RC-12

4.0 - EXPLODED VIEW AND PARTS LIST

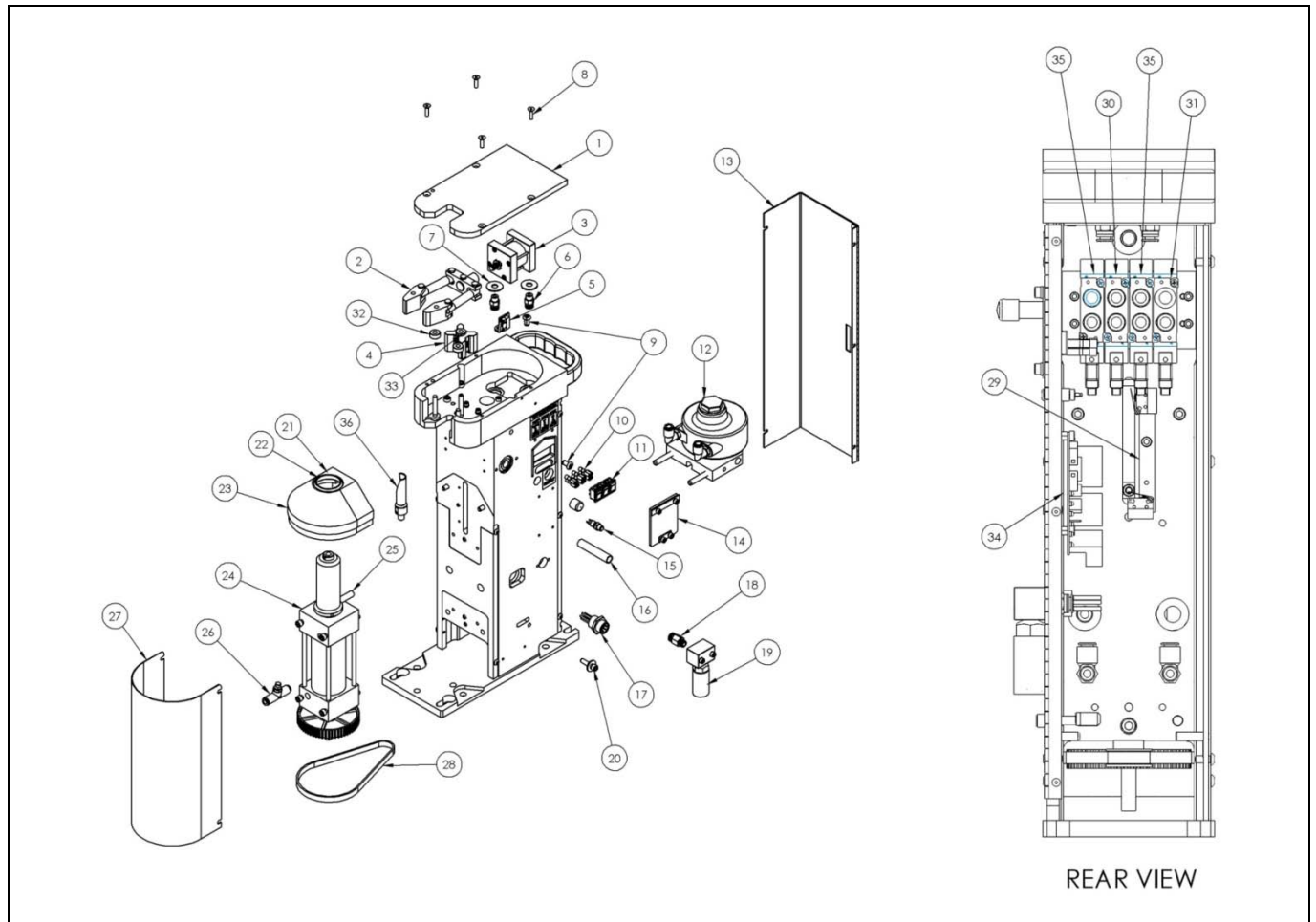

PART #	DESCRIPTION	COMMON WITH PREVIOUS MODEL	PART #	DESCRIPTION	COMMON WITH PREVIOUS MODEL
1	R-2110 CLAMP COVER	N	19	TR-2530 MUFFER	Y
2	TR-2120 JAW ASSEMBLY	Y	20	TR-2632 TENSION LOCK WASHER	Y
3	TR-2130 CLAMP CYLINDER	Y	21	TR-2662 RUBBER GASKET	Y
4	V-BLOCK SEE PAGES 12 FOR CHART	N	22	TR-2661 SPINDLE CAP SEAL	Y
5	TR-2321 CLAMP LIMIT SWITCH ASSEMBLY	Y	23	TR-2660 SPINDLE CAP	Y
6	TR-2232 AIR FITTING 1/4" SMC (2)	Y	24	TT-2400 SPINDLE ASSEMBLY	Y
7	TR-2239 RING GASKET - .062" THICK	Y	25	TR-2411 SPINDLE SWITCH - ACTUATOR	Y
8	NON-SELLABLE SCREWS SCHCS M5 X .8 X 16 LONG	N	26	TR-2234 FLOW CONTROL	Y
9	TR-2452 GROMMET (2)	Y	27	TT-2670 REAMER SPINDLE SHROUD	Y
10	412-5 FEMALE SPADE CONNECTOR	N	28	TR-2440 REAMER DRIVE BELT	Y
11	411-12-6 ROCKER SWITCH	N	29	TT-2322 LIMIT SWITCH ASSEMBLY	Y
12	TR-2500 AIR MOTOR ASSEMBLY	Y	30	R-2247 SPRAYER VALVE WITH PLUG	N
13	R-2680 REAR COVER ASSEMBLY	N	31	R-2248 MOTOR VALVE WITH PLUG	N
14	R-2601 REAMER SWITCH COVER ASSEMBLY	N	32	TR-2127 FRONT JAW SPACER - 2 REQUIRED	Y
15	TT-2330 RESET SWITCH ASSEMBLY	Y	33	TR-2128 REAR JAW SPACE - 1 REQUIRED	Y
16	R-2245 1/8" NPT 3" LG. NIPPLE, GALVANIZED	N	34	TR-2310 REAMER CIRCUIT BOARD	Y
17	TR-2340 INTERFACE RECEPTACLE	Y	35	R-2241 CLAMP / SPINDLE VALVE	N
18	TR-2231 5/16" X 1/8" NPT PUSH-TO-CONNECT FITTING	Y	36	CUTTER BLADE (SEE Section 3.3 CUTTER BLADE AND V-BLOCK CHART FOR COMPLETE LIST)	Y

5.0 – TROUBLESHOOTING

PROBLEM	POSSIBLE CAUSE	SOLUTION
LED SIGNALS NOT ACTIVATING	<ul style="list-style-type: none"> CIRCUIT BOARD DAMAGED LIMIT SWITCH MALFUNCTIONING INPUT VOLTAGE IS INCORRECT 	<ul style="list-style-type: none"> REPLACE BOARD REPLACE SWITCH CHECK INPUT VOLTAGE AND MAKE ADJUSTMENTS AS REQUIRED
MOTOR STOPS DURING OPERATION	<ul style="list-style-type: none"> AIR SUPPLY IS INCORRECT EXCESSIVE SPATTER BUILD-UP LUBRICATOR NOT INSTALLED OR ADJUSTED PROPERLY 	<ul style="list-style-type: none"> SET AT 80-100 PSI AT 16 CFM APPLY OR INCREASE QUANTITY OF ANTI-SPATTER INCREASE FREQUENCY OF TORCH CLEANING OR MODIFY WELDING PARAMETERS ENSURE LUBRICATOR IS INSTALLED AND ADJUSTED (SEE Section 1.2 AIR MOTOR LUBRICATION)
PNEUMATIC FUNCTIONS NOT OPERATIVE	<ul style="list-style-type: none"> AIR LINE DAMAGED OR OBSTRUCTED AIR SUPPLY INCORRECT FAULTY RESET SWITCH MANUAL SWITCHES ENGAGED 	<ul style="list-style-type: none"> REPLACE AIR LINE CHECK AIR SUPPLY. SET AT 80-100 PSI AT 16 CFM REPAIR OR REPLACE RESET SWITCH TURN OFF MANUAL SWITCHES
BROKEN CUTTER	<ul style="list-style-type: none"> IMPROPER CUTTER BEING USED FLOW CONTROL VALVE SET TOO FAST GUN IMPROPERLY ALIGNED IN REAMER 	<ul style="list-style-type: none"> REPAIR OR REPLACE DAMAGED COMPONENTS ADJUST FEED RATE ADJUST FLOW CONTROL VALVE
TOUGH GUN REAMER STAYS IN UP POSITION	<ul style="list-style-type: none"> CUTTER IS JAMMED IN GUN FAULTY SPINDLE UNIT FAULTY LIMIT SWITCH CYCLE START SIGNAL HELD ON TOO LONG 	<ul style="list-style-type: none"> PRESS OR REPLACE DAMAGED COMPONENTS REPAIR OR REPLACE UNIT REPAIR OR REPLACE LIMIT SWITCH REVISE PROGRAM (0.5 SEC. PULSE).
CYCLE COMPLETE SIGNAL DOES NOT ACTIVATE	<ul style="list-style-type: none"> FAULTY CLAMP SWITCH FAULTY CIRCUIT BOARD 	<ul style="list-style-type: none"> CHECK OR REPLACE SWITCH

6.0 – SPRAYER (OPTION)

6.1 ANTI-SPATTER SPRAYER

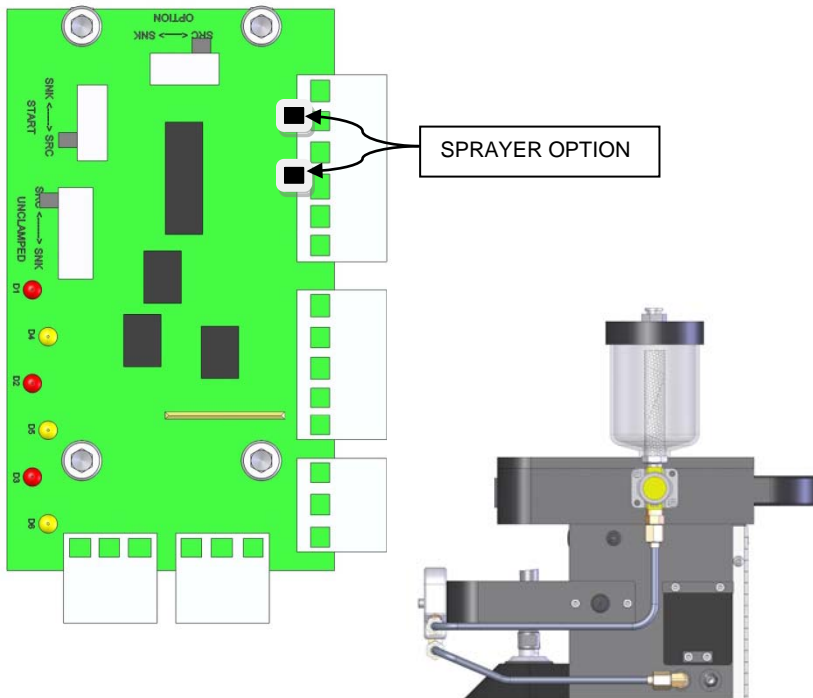

- The TOUGH GUN Sprayer is factory set for “Sourcing”. The wires are connected to the P.C. board as shown.
- If you require the P.C. board switches to be set to the “Sinking” position, the switch (SW1) must be moved to the “Sinking” position (identified on board).
- To operate the sprayer, a timed +24 VDC signal must be applied to the black lead (sprayer option) of the interface receptacle. Recommended spray time 0.5 seconds (Refer to Sprayer Tech Guide).

6.2 SPRAYER PROGRAMMING EVENTS SEQUENCE

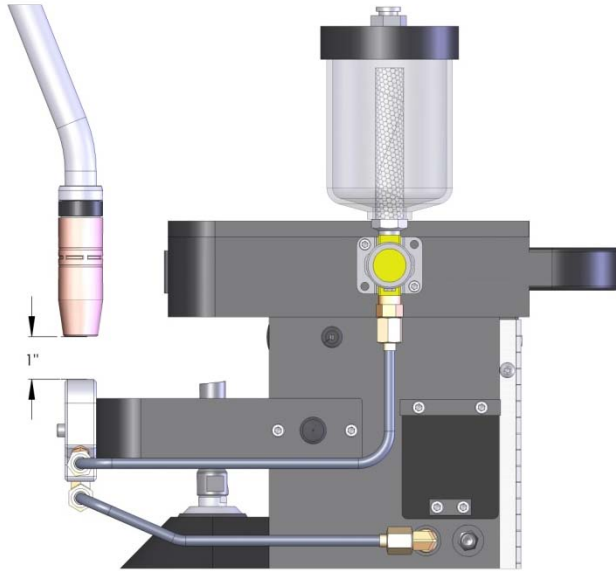

- Program robot so that nozzle is centrally located.
X = 1.25" when using 5/8" Bore Nozzles.
X = 1.0" when using 1/2" Bore Nozzles.
X = 1.5" when using 3/4" Bore Nozzles.
- Energize timed output signal to initiate spray cycle. Set timer at 0.5 seconds for initial set-up. Adjust timer to increase or decrease quantity of anti-spatter compound as required by process.
- **NOTE:** If using Tregaskiss TOUGH GARD™ Anti-Spatter Compound, spray time can be as low as 0.2 seconds. Anti-spatter compound should be enough to coat inside of nozzle with no drippage. Excessive application of TOUGH GARD Anti-Spatter can decrease performance and increase consumption.
- **IMPORTANT:** If using the optional air-blast, **DO NOT** activate air blast when over the spray head. Dirt / spatter may be blown into the spray head orifice, which may hamper spray operation.

6.3 SPRAYER MAINTENANCE

DAILY

- Ensure fluid level in reservoir is maintained. Inspect spray operation to ensure adequate anti-spatter compound is being applied.

WEEKLY

- Inspect unit for air leaks or damaged supply and interface lines which may cause unit to malfunction.

QUARTERLY

- Inspect unit for buildup of residue from anti-spatter compound which could eventually restrict fluid flow or cause unit to malfunction. Residue should be visible in reservoir or nozzle assembly. If excessive, clean or flush with recommended solvent or anti-spatter compound.

YEARLY

- Inspect unit for damage or excessive wear of components. Replace if required.

6.4 SPRAYER TROUBLESHOOTING

PROBLEM	POSSIBLE CAUSE	SOLUTION
NO AIR FLOW NO ANTI-SPATTER	<ul style="list-style-type: none"> • OUTPUT TO UNIT NOT FUNCTIONING • LOSS OF AIR SUPPLY • FAULTY SOLENOID VALVE • SINK / SOURCE 	<ul style="list-style-type: none"> • CHECK OUTPUT SIGNAL AND CABLE • CHECK AIR SUPPLY • CHECK AIR LINE AND NOZZLE FOR BLOCKAGE • CHECK SOLENOID VALVE AND REPLACE IF REQUIRED • ADJUST SINK / SOURCE SWITCH FOR SPRAY OPTION (FIG. 6.1)
AIR FLOW BUT NO ANTI-SPATTER	<ul style="list-style-type: none"> • VENT CLOSED ON RESERVOIR • SPOOL IN CHECK VALVE STUCK • FLUID LINE BLOCKED 	<ul style="list-style-type: none"> • OPEN VENT • REPAIR OR REPLACE CHECK VALVE • CLEAN OR REPAIR FLUID LINE
SPRAY HEAD PLUGGED	<ul style="list-style-type: none"> • DEBRIS IN SPRAY HEAD 	<ul style="list-style-type: none"> • CLEAN SPRAY HEAD

6.5 SPRAYER PARTS LIST - SR-500

TECHNICAL DATA

Electrical: 24 volts DC 2.5 watts
 Pneumatic: 80-100 psi at 16 CFM
 (Uses Reamer Air Supply)

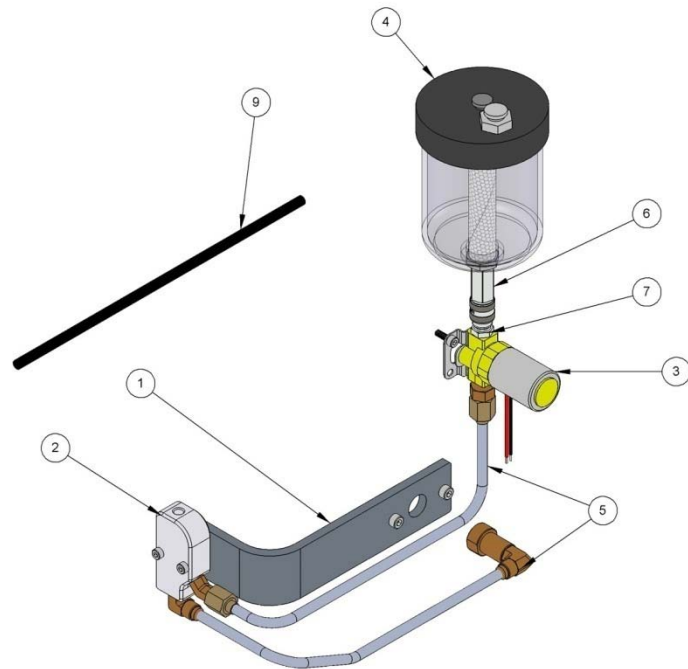

ITEM	PART #	DESCRIPTION
1	SR-500-1	SPRAY HEAD BRACKET
2	TS-500-15	SPRAY HEAD
3	SR-500-20	CHECK VALVE - SMC
4	RR-1320	RESERVOIR
5	SR-500-50	SPRAYER STEEL LINE KIT
6	TS-500-40-1	FEMALE QUICK CONNECT
7	TS-500-40-2	MALE QUICK CONNECT
	TS-500-40	QUICK CONNECT ASSEMBLY (INCLUDES MALE & FEMALE)
9	TR-2237	1/4" TUBING - 8" LONG

7.0 - ADDITIONAL OPTIONS

7.1 REAMER STAND WITH OPTIONAL SMC FRL (FILTER REGULATOR LUBRICATOR)

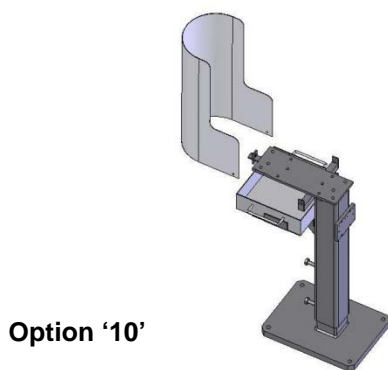

PART #	DESCRIPTION
RST-1000-A	ADJUSTABLE REAMER STAND (28" TO 43")

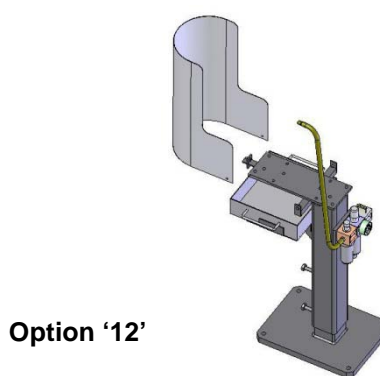

PART #	DESCRIPTION
RST-1200-A	ADJUSTABLE REAMER STAND WITH SMC FRL (28" TO 43")

7.2 FLOW CONTROL

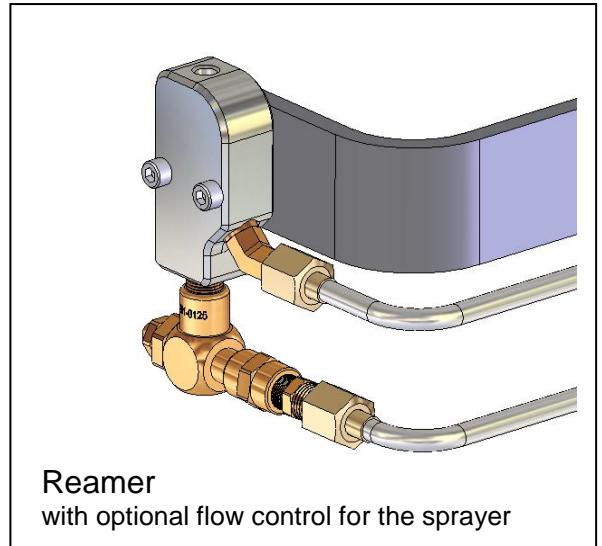
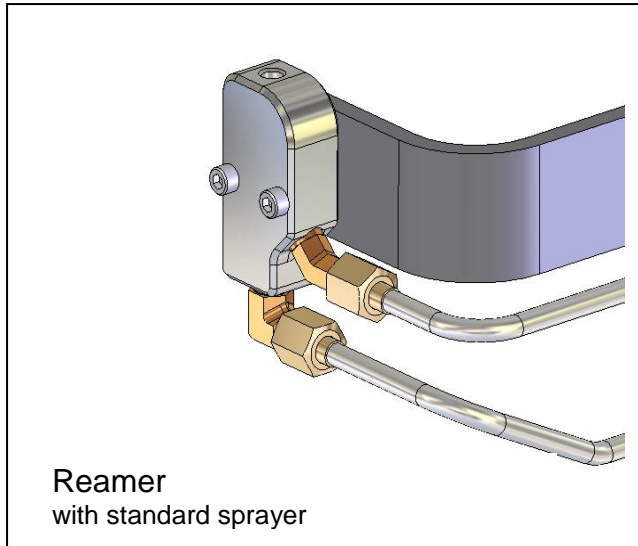

NOTE: Choosing Reamer option 'C' - Flow Control adds an adjustable check valve, giving users the ability to control the amount of TOUGH GARD Anti-Spatter applied in each spray.
Also available: the retrofitable flow control kit (Part #SR-500-55).

7.3 WIRE CUTTER

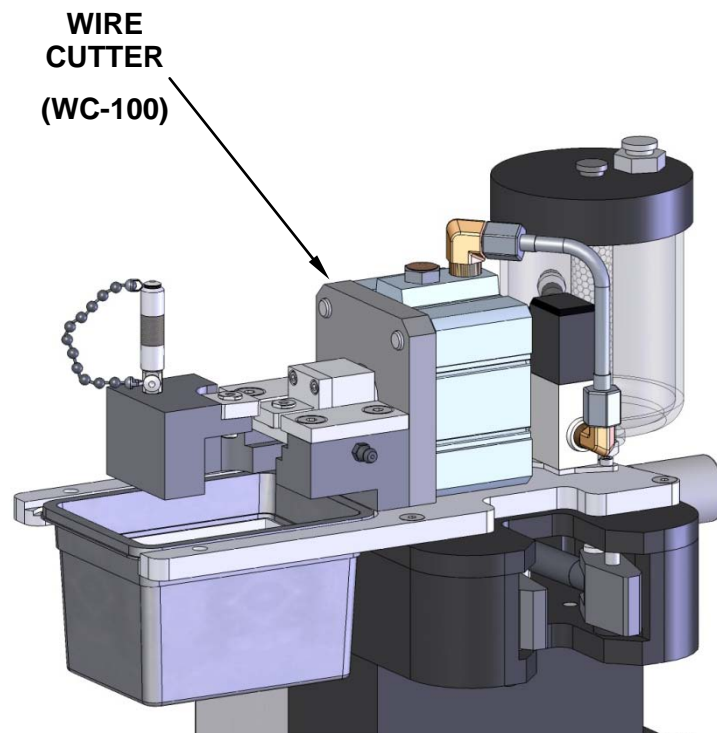

8.0 – MULTI-FEED READY REAMER

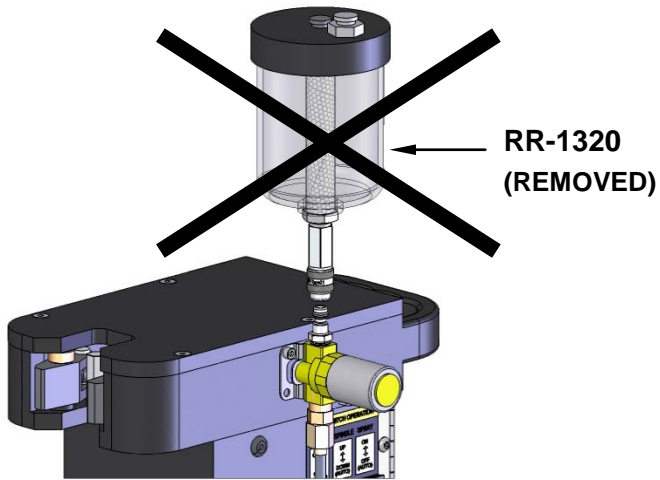

All Reamers are multi-feed ready by removing the sprayer reservoir (RR-1320) since it is not needed with the Multi-Feed System.

A diagram below shows one of many Multi-Feed configurations. Refer to our website or your local Tregaskiss representative for more information.

NOTE:
Multi-Feed Systems are sold separately.

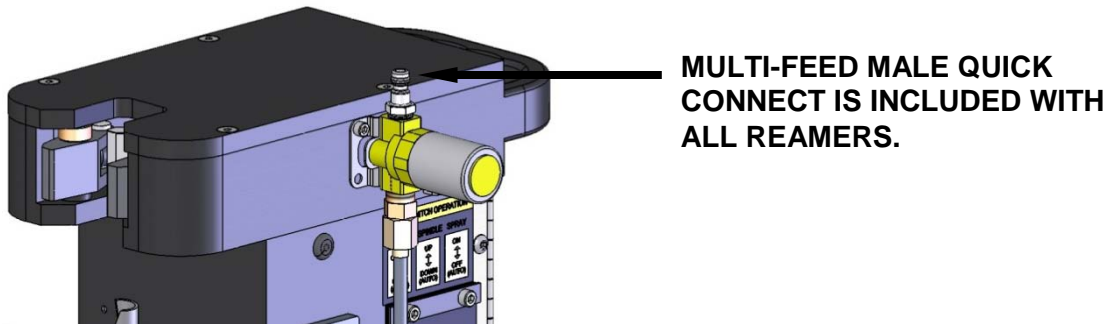

TOUGH GARD MULTI-FEED SYSTEM

PART #	DESCRIPTION
CHOOSE 1	
TG-103-05-2	5 GALLON PAIL (UP TO 2 REAMERS)
TG-105-05-10	5 GALLON PAIL (UP TO 10 REAMERS)
TG-103-55-2	55 GALLON DRUM (UP TO 2 REAMERS)
TG-103-55-10	55 GALLON PAIL (UP TO 10 REAMERS)
HOSE (SOLD SEPARATELY)	
TG-103-50	50' MULTI-FEED HOSE (UV RATED)
TG-103-100	100' MULTI-FEED HOSE (UV RATED)
TG-103-200	200' MULTI-FEED HOSE (UV RATED)
REPLACEMENT PARTS	SEE M055 TECH GUIDE

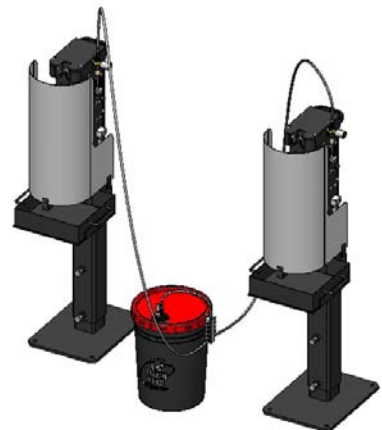

9.0 – ORDERING INFORMATION

Building a TOUGH GUN Reamer part number

TT – XXXX – XX – XX – XX

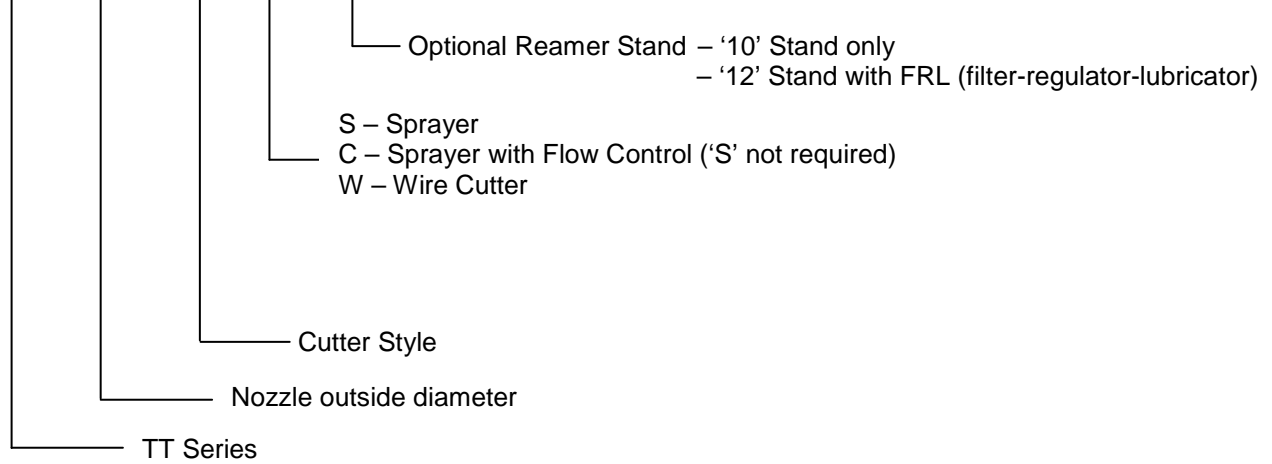

Order Number Examples:

TT – 0938 – 01 – 3 – W – 10

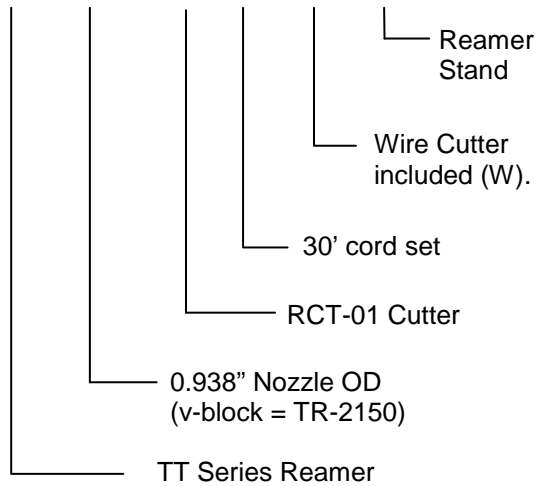

TT – 1060 – 01 – 5 – SW – 12

